

**SPLIT TYPE
ROOM AIR CONDITIONER
WALL MOUNTED^{type}
INVERTER**

SERVICE INSTRUCTION

Models	Indoor unit	Outdoor unit
	ASU18RLF	AOU18RLXFWH
	ASU24RLF	AOU24RLXFWH

Refrigerant
R410A

CONTENTS

1. DESCRIPTION OF EACH CONTROL OPERATION

1. COOLING OPERATION.....	01-01
2. HEATING OPERATION.....	01-02
3. DRY OPERATION.....	01-02
4. AUTO CHANGEOVER OPERATION.....	01-03
5. INDOOR FAN CONTROL.....	01-04
6. OUTDOOR FAN CONTROL.....	01-06
7. LOUVER CONTROL.....	01-07
8. COMPRESSOR CONTROL.....	01-08
9. TIMER OPERATION CONTROL.....	01-09
10. ELECTRONIC EXPANSION VALVE CONTROL.....	01-11
11. TEST OPERATION CONTROL.....	01-11
12. PREVENT TO RESTART FOR 3 MINUTES (3 MINUTES ST).....	01-11
13. FOUR-WAY VALVE EXTENSION SELECT.....	01-11
14. AUTO RESTART.....	01-12
15. MANUAL AUTO OPERATION (INDOOR UNIT BODY OPERATION).....	01-12
16. FORCED COOLING OPERATION.....	01-12
17. COMPRESSOR PREHEATING.....	01-13
18. MINIMUM HEAT OPERATION.....	01-13
19. ECONOMY OPERATION.....	01-13
20. BASE HEATER OPERATION.....	01-13
21. HEAT INSULATION CONDITION (BUILDING INSULATION).....	01-14
22. THERMO CONTROL (FOR INDOOR UNIT SENSOR).....	01-14
23. THERMO CONTROL (FOR WIRED REMOTE SENSOR).....	01-14
24. DEFROST OPERATION CONTROL.....	01-15
25. OFF DEFROST OPERATION CONTROL.....	01-17
26. VARIOUS PROTECTIONS.....	01-18

2. TROUBLE SHOOTING

2-1 ERROR DISPLAY.....	02-01
2-1-1 INDOOR UNIT AND WIRED REMOTE CONTROLLER DISPLAY	02-01
2-1-2 WIRED REMOTE CONTROLLER DISPLAY.....	02-02
2-2 TROUBLE SHOOTING WITH ERROR CODE.....	02-03
2-3 TROUBLE SHOOTING WITH NO ERROR CODE.....	02-25
2-4 SERVICE PARTS INFORMATION.....	02-34

3. APPENDING DATA

3-1 FUNCTION SETTING.....	03-01
3-1-1 INDOOR UNIT.....	03-01
3-1-2 PROCEDURE TO CHANGE THE FUNCTION SETTING FOR WIRELESS RC.....	03-05
3-2 OUTDOOR UNIT PRESSURE VALUE AND TOTAL ELECTRIC CURRENT CURVE	03-07
3-3 THERMISTOR RESISTANCE VALUES.....	03-11

WALL MOUNTED type INVERTER

1 . DESCRIPTION OF EACH CONTROL OPERATION

1. COOLING OPERATION

A sensor (room temperature thermistor) built in the indoor unit body will usually perceive difference or variation between a set temperature and present room temperature, and controls the operation frequency of the compressor.

- * If the room temperature is 7°F(3.5°C) higher than a set temperature, the compressor operation frequency will attain to maximum performance.
- * If the room temperature is 1°F(0.5°C) lower than a set temperature, the compressor will be stopped.
- * When the room temperature is between +7°F(+3.5°C) to -1°F(-0.5°C) of the setting temperature, the compressor frequency is controlled within the range shown in Table 1.

However, the maximum frequency is limited in the range shown in Fig. 1 based on the fan speed mode and the outdoor temperature.

(Table 1 : Compressor frequency range)

	Minimum frequency	Maximum frequency
AOU18RLXFWH	12rps	55rps
AOU24RLXFWH	16rps	72rps

(Fig.1 : Limit of maximum frequency based on outdoor temperature)

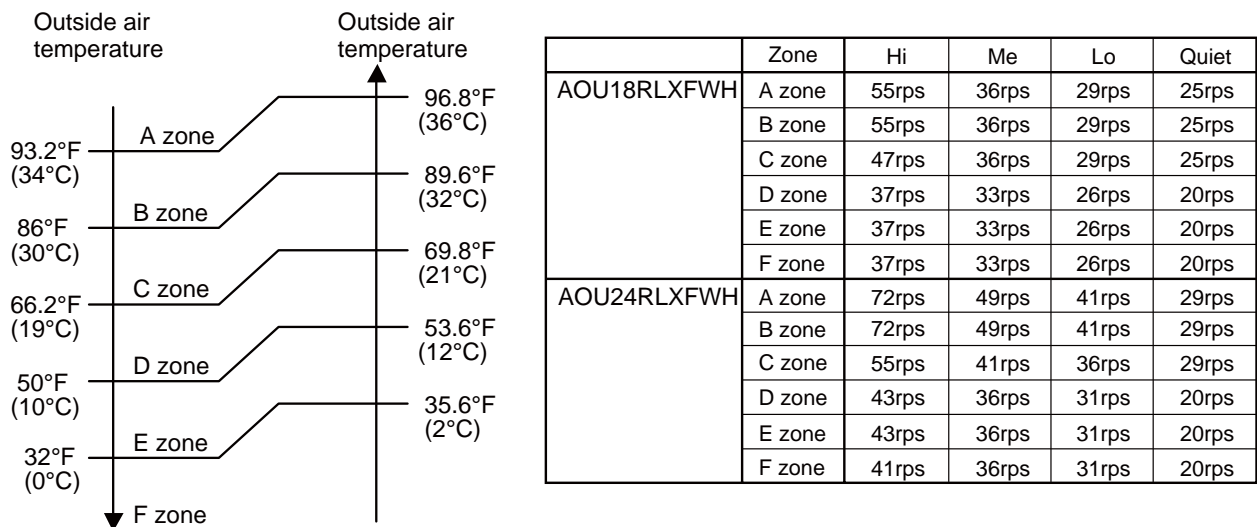

2. HEATING OPERATION

A sensor (room temperature thermistor) built in the indoor unit body will usually perceive difference or variation between a set temperature and present room temperature, and controls the operation frequency of the compressor.

- * If the room temperature is lower by 9°F(4.5°C) than a set temperature, the compressor operation frequency will attain to maximum performance.
- * If the room temperature is higher 1°F(0.5°C) than a set temperature, the compressor will be stopped.
- * When the room temperature is between +1°F(+0.5°C) to -9°F(-4.5°C) of the setting temperature, the compressor frequency is controlled within the range shown in Table 2.

(Table 2 : Compressor frequency range)

	Minimum frequency	Maximum frequency
AOU18RLXFWH	14rps	67rps
AOU24RLXFWH	16rps	90rps

3. DRY OPERATION

The compressor rotation frequency shall change according to the temperature, set temperature, and room temperature variation which the room temperature sensor of the indoor unit body has detected as shown in the Table 3.

However, after the compressor is driven, the indoor unit shall run at operation frequency of 30rps (ASU18RLF), 30rps (ASU24RLF), for a minute.

(Table 3 : Compressor frequency)

		Operating frequency			Operating frequency
AOU18RLXFWH	X zone	25rps	AOU24RLXFWH	X zone	29rps
	J zone	15rps		J zone	16rps
	Y zone	0rps		Y zone	0rps

(Fig. 2 : Compressor control based on room temperature)

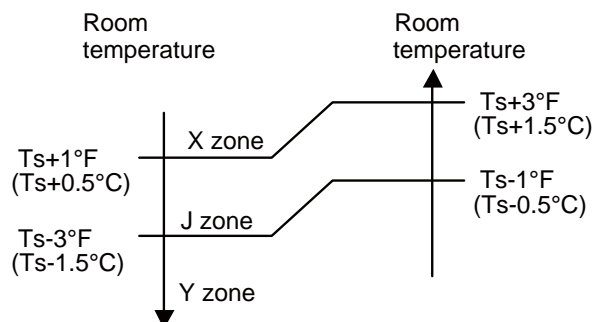

4. AUTO CHANGEOVER OPERATION

When the air conditioner is set to the AUTO mode by remote control, operation starts in the optimum mode from among the HEATING, COOLING and MONITORING modes.
 During operation, the optimum mode is automatically switched in accordance with temperature changes.
 The temperature can be set between 64°F(18°C) and 86°F(30°C) in 2°F(1°C) steps.

■ AUTO CHANGEOVER operation flow chart

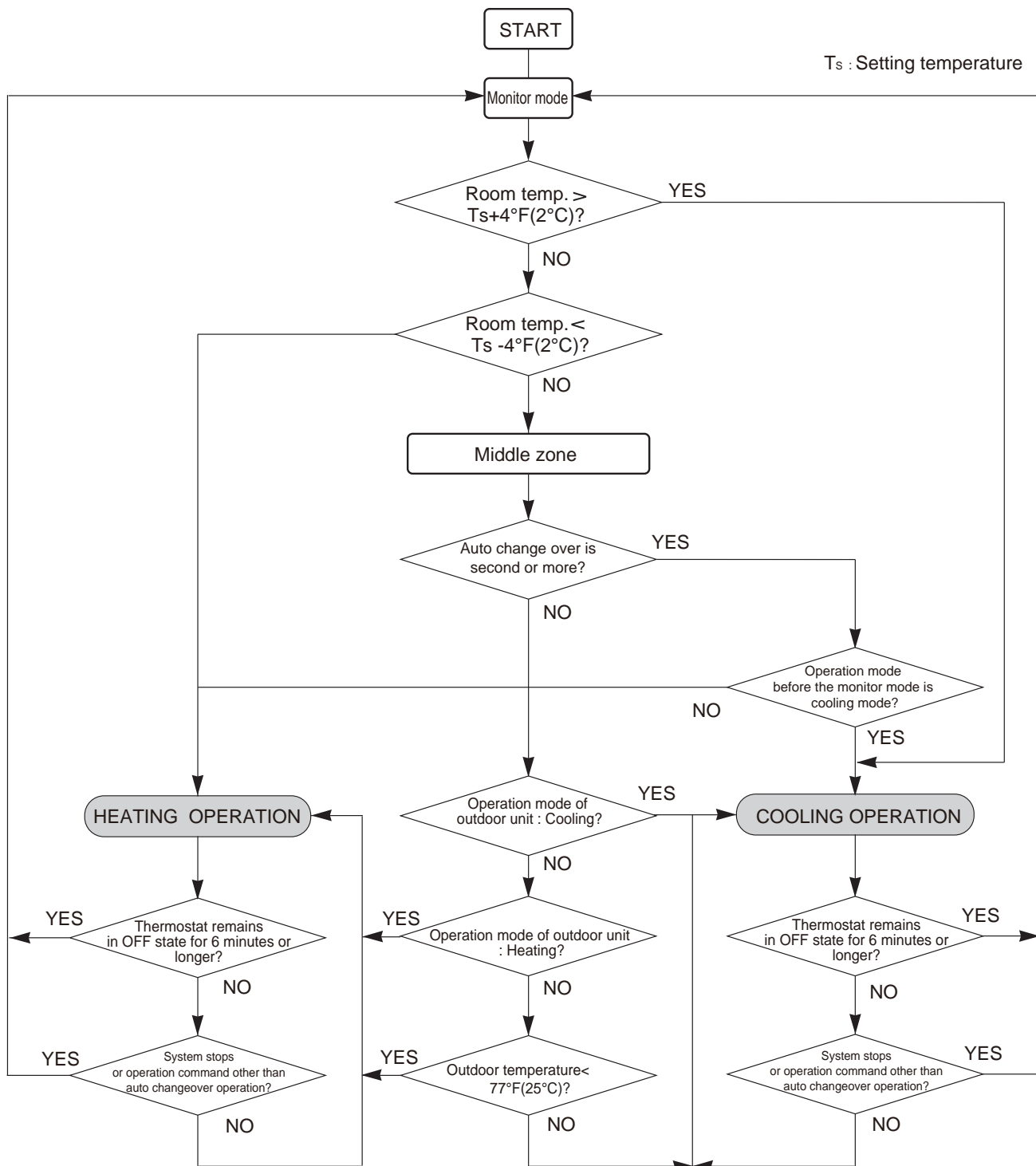

5. INDOOR FAN CONTROL

1. Fan speed

(Table 4 : Indoor fan speed)

Operation mode	Air flow mode	Speed (rpm)	
		ASU18RLF	ASU24RLF
Heating	Hi	1260	1530
	Me+	1120	1320
	Me	1020	1220
	Lo	900	1020
	Quiet	790	900
	Cool air prevention	680	720
	S-Lo	270	270
Cooling/ Fan	Hi	1260	1480
	Me	1020	1220
	Lo	900	1020
	Quiet	770	900
Dry		X zone : 770 J zone : 720	X zone : 900 J zone : 850

2. FAN OPERATION

The airflow can be switched in 5 steps such as AUTO, QUIET, LOW, MED, HIGH, while the indoor fan only runs.

When Fan mode is set at (Auto), it operates on (MED) Fan Speed.

3. COOLING OPERATION

Switch the airflow [AUTO], and the indoor fan motor will run according to a room temperature, as shown in Fig. 3.

On the other hand, if switched in [HIGH] ~ [QUIET], the indoor motor will run at a constant airflow of [COOL] operation modes QUIET, LOW, MED, HIGH, as shown in Table 4.

(Fig. 3 : Airflow change - over (Cooling : AUTO))

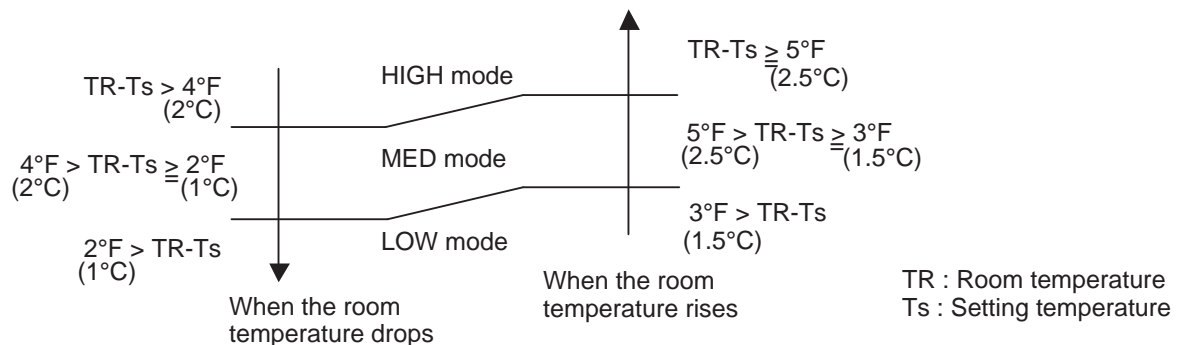

4. DRY OPERATION

Refer to the Table 4.

During the dry mode operation, the fan speed setting can not be changed.

5. HEATING OPERATION

Switch the airflow [AUTO], and the indoor fan motor will run according to a room temperature, as shown in Fig. 4.

On the other hand, if switched in [HIGH] ~ [QUIET], the indoor motor will run at a constant airflow of [HEAT] operation modes QUIET, LOW, MED, HIGH, as shown in Table 4.

(Fig. 4 : Airflow change - over (Heating : AUTO))

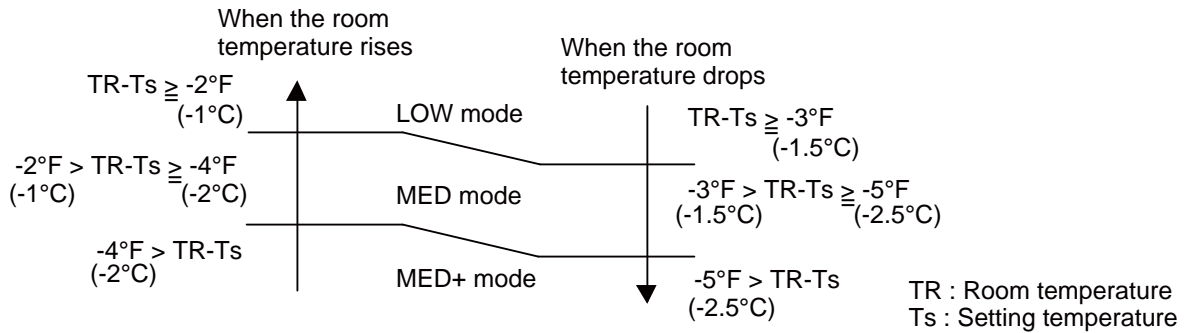

6. COOL AIR PREVENTION CONTROL (Heating mode)

The maximum value of the indoor fan speed is set as shown in Fig.5, based on the detected temperature by the indoor heat exchanger sensor on heating mode.

When the compressor does not operate, the indoor fan motor operates [S-Lo] or [Stop] mode.

(Fig .5 : Cool Air Prevention Control)

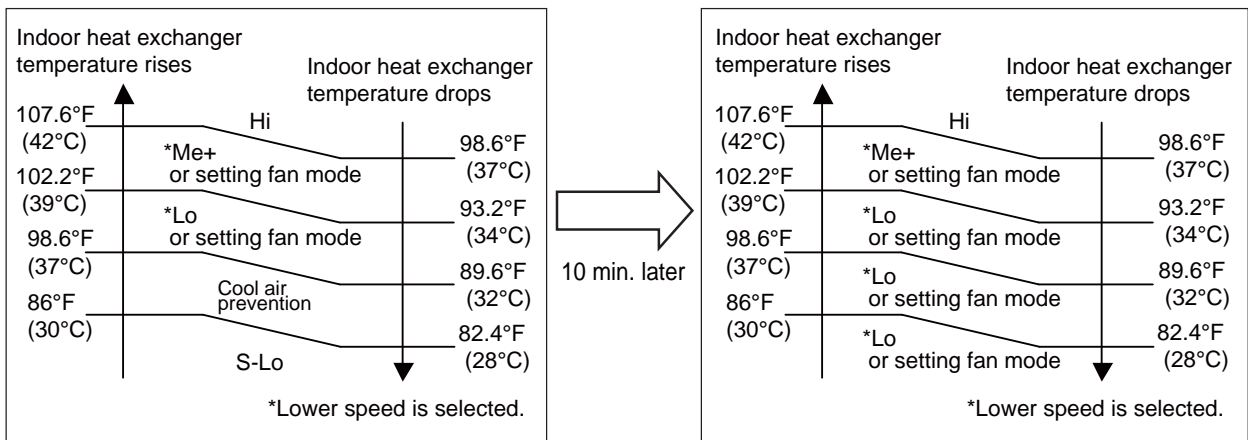

6. OUTDOOR FAN CONTROL

1. Outdoor Fan Motor

Following table shows the type of the outdoor fan motor.
The control method is different between AC motor and DC motor.

(Table 5 : Type of motor)

	AC Motor	DC Motor
AOU18 / 24RLXFWH		○

2. Fan Speed

(Table 6 : Outdoor fan speed)

	Zone ※	Cooling	Heating	Dry
AOU18RLXFWH	D	800/ 620/ 500/ 400	800/ 620/ 550/ 450	550/ 450
	F	500/ 320/ 250		
	G	300/ 230/ 200		
	H	220/ 200		
AOU24RLXFWH	D	850/ 800/ 620/ 500/ 400	900/ 850/ 800/ 620/ 550/ 450	550/ 450
	F	500/ 320/ 250		
	G	300/ 230/ 200		
	H	220/ 200		

※ Refer to Fig.6

(Fig. 6 : Outside air temperature zone selection)

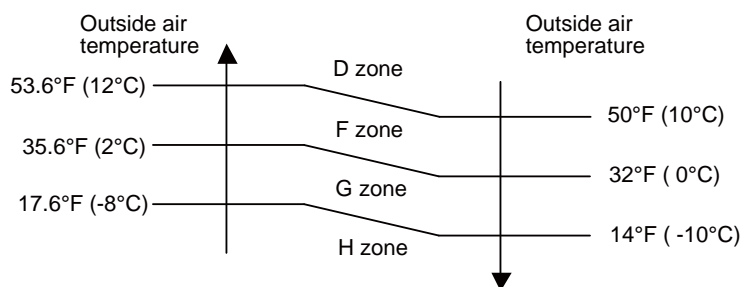

- * The outdoor fan speed mentioned above depends on the compressor frequency.
(When the compressor frequency increases, the outdoor fan speed also changes to the higher speed. When the compressor frequency decreases, the outdoor fan speed also changes to the lower speed.)
- * After the defrost control is operated on the heating mode, the fan speed keeps at the higher speed as Table 7 without relating to the compressor frequency.

(Table 7 : Outdoor fan speed after the defrost)

	Fan speed
AOU18RLXFWH	800rpm
AOU24RLXFWH	900rpm

7. LOUVER CONTROL

1. VERTICAL LOUVER CONTROL

(Function Range)

Each time the button is pressed, the air direction range will change as follow:

① ⇄ ② ⇄ ③ ⇄ ④ ⇄ ⑤ ⇄ ⑥

(Fig. 7 : Vertical air direction range)

Use the air direction adjustments within the ranges shown above.

- The vertical airflow direction is set automatically as shown, in accordance with the type of operation selected.

Cooling / Dry mode : Horizontal flow ①
 Heating mode : Downward flow ⑤

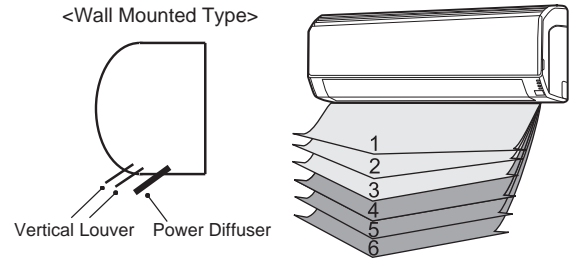

- When the temperature of the air being blown out is low at the start of heating operation or during defrosting, the airflow direction temporarily becomes ① to prevent cold air being blown onto the body.
- During use of the Cooling and Dry modes, do not set the Air Flow Direction Louver in the Heating range (④ ~ ⑥) for long period of time, since water vapor may condense near the outlet louvers and drop of water may drip from the air conditioner. During the Cooling and Dry modes, if the Air Flow Direction Louvers are left in the heating range for around 20 minutes, they will automatically return to position ③.

2. HORIZONTAL LOUVER CONTROL

(Function Range)

Each time the button is pressed, the air direction range will change as follows.

Cooling / Heating / Dry / Fan mode ① ⇄ ② ⇄ ③ ⇄ ④ ⇄ ⑤

(Fig. 8 : Horizontal air direction range)

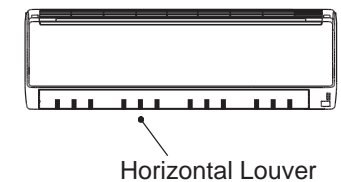

3. SWING OPERATION

Vertical Airflow Swing Operation

When the swing signal is received from the remote controller, the vertical louver starts to swing.

(Table 8 : Vertical swinging range)

Operation mode	Range
Cooling / Dry mode Fan mode (① ⇄ ③)	① ⇄ ④
Heating mode Fan mode (④ ⇄ ⑥)	③ ⇄ ⑥

- When the indoor fan is S-Lo or Stop mode, the swing operation is interrupted and it stops at either upper end or bottom end.

Horizontal Airflow Swing Operation

When the swing signal is received from the remote controller, the horizontal louver starts to swing.

(Table 9 : Horizontal swinging range)

Operation mode	Range
Cooling / Dry / Heating / Fan mode	① ⇄ ⑤

- When the indoor fan is S-Lo or Stop mode, the swing operation is interrupted and it stops at either upper end or bottom end.

Vertical and Horizontal Airflow Swing Operation

- When the horizontal swing signal is input from remote control, the combination of the vertical and horizontal swing operation is performed.

※ Power Diffuser doesn't swing in any swing operation.

8. COMPRESSOR CONTROL

1. OPERATION FREQUENCY RANGE

The operation frequency of the compressor is different based on the operation mode as shown in the Table 10.

(Table 10 : Compressor operation frequency range)

	Cooling		Heating		Dry	
	Min	Max	Min	Max	Min	Max
AOU18RLXFWH	12rps	55rps	14rps	67rps	15rps	25rps
AOU24RLXFWH	16rps	72rps	16rps	90rps	16rps	29rps

2. OPERATION FREQUENCY CONTROL AT START UP

The compressor frequency soon after the start-up is controlled as shown in the Fig 9.

(Fig. 9 : Compressor Control at Start-up)

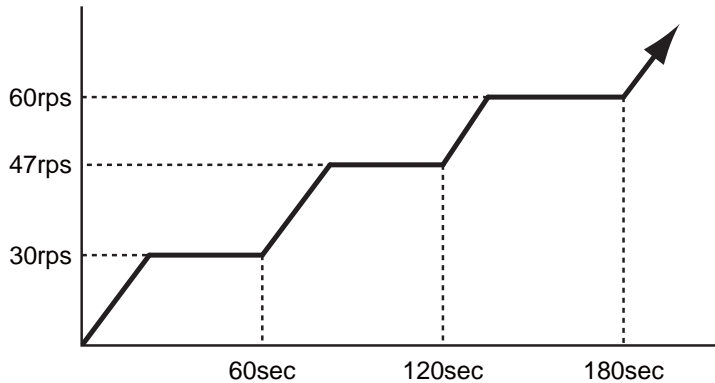

3. LIMITATION OF COMPRESSOR FREQUENCY BY OUTDOOR TEMPERATURE

The minimum compressor frequency is limited by outdoor temperature as shown in the Table 11.

(Table 11 : Limitation of compressor frequency)

[Cooling/ Dry]

	14°F (-10°C)		32°F (0°C)		50°F (10°C)		100°F (38°C)	
	Under	Over	Under	Over	Under	Over	Under	Over
AOU18RLXFWH	40rps	32rps	25rps	12rps	25rps			

	14°F (-10°C)		32°F (0°C)		50°F (10°C)		100°F (38°C)	
	Under	Over	Under	Over	Under	Over	Under	Over
AOU24RLXFWH	40rps	32rps	25rps	16rps	25rps			

[Heating]

	14°F (-10°C)		44.6°F (7°C)	
	Under	Over	Under	Over
AOU18RLXFWH	40rps	25rps	16rps	

	14°F (-10°C)		34°F (1°C)		46.4°F (8°C)	
	Under	Over	Under	Over	Under	Over
AOU24RLXFWH	40rps	25rps	19rps	16rps		

9. TIMER OPERATION CONTROL

The Table 12 shows the available timer setting based on the product model.

(Table 12 : Timer setting)

	ON TIMER / OFF TIMER	PROGRAM TIMER	SLEEP TIMER
ASU18 / 24RLF	○	○	○

1. ON TIMER / OFF TIMER

- OFF timer : When the clock reaches the set time, the air conditioner will be turned off.

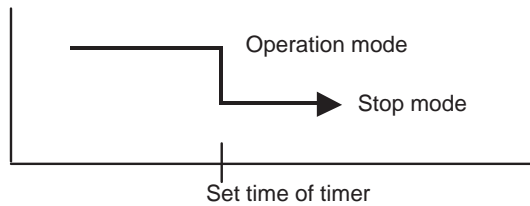

- ON timer : When the clock reaches the set time, the air conditioner will be turned on.

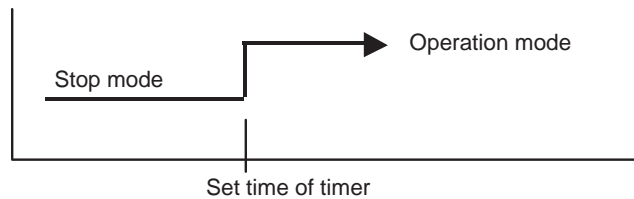

2. PROGRAM TIMER

- The program timer allows the OFF timer and ON timer to be used in combination one time.

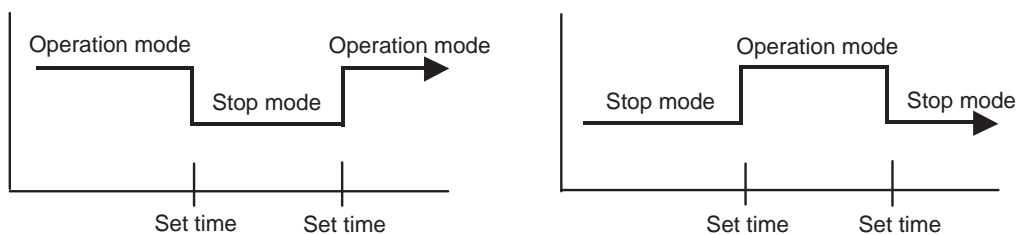

- Operation will start from the timer setting (either OFF timer or ON timer) whichever is closest to the clock's current timer setting.
The order of operations is indicated by the arrow in the remote control unit's display.
- SLEEP timer operation cannot be combined with ON timer operation.

3. SLEEP TIMER

If the sleep is set, the room temperature is monitored and the operation is stopped automatically. If the operation mode or the set temperature is change after the sleep timer is set, the operation is continued according to the changed setting of the sleep timer from that time ON.

In the cooling operation mode

When the sleep timer is set, the setting temperature is increased 2°F(1°C). It increases the setting temperature another 2°F(1°C) after 1 hour. After that, the setting temperature is not changed and the operation is stopped at the time of timer setting.

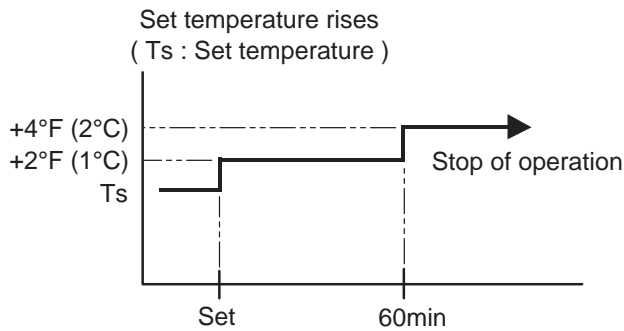

In the heating operation mode

When the sleep timer is set, the setting temperature is decreased 2°F(1°C). It decreases the setting temperature another 2°F(1°C) every 30 minutes. Upon lowering 8°F(4°C) the setting temperature is not changed and the operation stops at the time of timer setting.

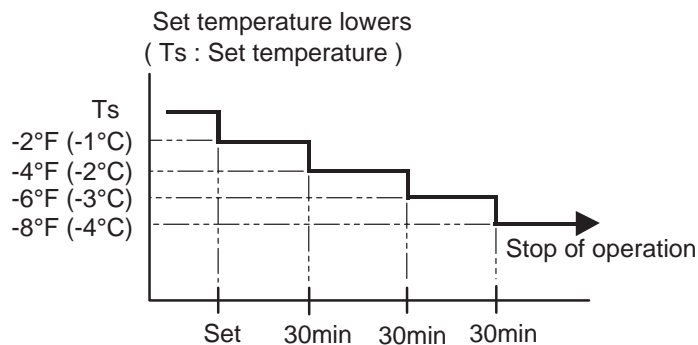

10. ELECTRONIC EXPANSION VALVE CONTROL

The most proper opening of the electronic expansion valve is calculated and controlled under the present operating condition based on the Table 13.

The compressor frequency, the temperatures detected by the discharge temperature sensor, the indoor heat exchanger sensor, the outdoor heat exchanger sensor, and the outdoor temperature sensor.

(Table 13 : The pulse range of the electronic expansion valve control)

	Operation mode	Pulse range
AOU18RLXFWH	Cooling / Dry mode	between 52 to 480 pulses.
	Heating mode	between 40 to 480 pulses.
AOU24RLXFWH	Cooling / Dry mode	between 53 to 480 pulses.
	Heating mode	between 40 to 480 pulses.

- * The expansion valve is set at 480 pulses after 120 seconds of stopping compressor.
- * At the time of supplying the power to the outdoor unit, the initialization of the electronic expansion valve is operated (528 pulses are input to the closing direction).

11. TEST OPERATION CONTROL

[Wireless remote controller]

The outdoor unit may not operate depending on the room temperature.
In this case, press the test run button on the remote controller while the air conditioner is running.
To end test operation, press the remote controller START/STOP button.
(When the air conditioner is running by pressing the test run button, the OPERATION Lamp and TIMER Lamp will simultaneously flash slowly.

[Using the Wired remote controller (Option)]

Stop the air conditioner operation.
Press the master control button and the fan control button simultaneously for 2 seconds or more to start the test run.
Press the start / stop button to stop the test run.

12. PREVENT TO RESTART FOR 3 MINUTES (3 MINUTES ST)

The compressor won't enter operation status for 3 minutes after the compressor is stopped, even if any operation is given.

13. FOUR-WAY VALVE EXTENSION SELECT

At the time when the air conditioner is switched from the cooling mode to heating mode, the compressor is stopped, and the four-way valve is switched in 3 minutes later after the compressor stopped.

14. AUTO RESTART

When the power was interrupted by a power failure, etc. during operation, the operation contents at that time are memorized and when power is recovered, operation is automatically started with the memorized operation contents.

When the power is interrupted and recovered during timer operation, since the timer operation time is shifted by the time the power was interrupted, an alarm is given by blinking (7 sec ON/2 sec OFF) the indoor unit body timer lamp.

[Operation contents memorized when the power is interrupted]

- Operation mode
- Set air flow
- Timer mode and timer time
- Set temperature
- Set air flow Direction
- Swing operation
- MINIMUM HEAT operation
- ECONOMY operation

15. MANUAL AUTO OPERATION (INDOOR UNIT BODY OPERATION)

If MANUAL AUTO Button is set, the operation is controlled as shown in Table 14.

If the remote control is lost or battery power dissipated, this function will work without the remote control.

(Table 14 : Manual auto switch operation)

	Manual auto operation
OPERATION MODE	Auto changeover
FAN CONT. MODE	Auto
TIMER MODE	Continuous (No timer setting available)
SETTING TEMP.	76°F (24°C)
SETTING LOUVER	Standard
SWING	OFF
ECONOMY	OFF

16. FORCED COOLING OPERATION

When FORCED COOLING OPERATION is set, the operation is controlled as shown is Table 15.

(Table 15 : Forced cooling operation)

	Forced cooling operation
OPERATION MODE	Cooling
FAN CONT. MODE	Hi
TIMER MODE	-
SETTING TEMP.	Room Temp is not controlled
SETTING LOUVER	Horizontal
SWING	OFF
ECONOMY	-

Forced cooling operation is started when pressing MANUAL AUTO button for 10 seconds or more. During the forced cooling operation, it operates regardless of room temperature sensor.

Forced cooling operation is released after 60 minutes of starting operation.

The FORCED COOLING OPERATION will start as shown in Table 15.

Operation LED and timer LED blink during the forced cooling operation. They blink for 1 second ON and 1 second OFF on both operation LED and timer LED (same as test operation).

17. COMPRESSOR PREHEATING

When the outdoor temperature is lower than 68°F(20°C) and the all operation mode has been stopped for 30 minutes, power is applied to the compressor and the compressor is heated. (By heating the compressor, warm air is quickly discharged when operation is started.)

When operation was started and when the outdoor temperature rises to 77°F(25°C) or greater, preheating is ended.

18. MINIMUM HEAT OPERATION

The MINIMUM HEAT operation functions by pressing MIN.HEAT button on the remote controller.

The MINIMUM HEAT operation is almost the same operation as below settings.

(Table 16 : Minimum heat operation)

Mode	Heating
Setting temperature	50°F (10°C)
Fan mode	AUTO

19. ECONOMY OPERATION

The ECONOMY operation functions by pressing ECONOMY button on the remote controller.

The ECONOMY operation is almost the same operation as below settings.

(Table 17 : Economy operation)

Mode	Cooling/ Dry	Heating
Target temperature	Setting temp.+2°F(+1°C)	Setting temp.-2°F(-1°C)

20. BASE HEATER OPERATION

The base heater is operated as shown in Fig. 10 .

(Fig.10 : Base heater control)

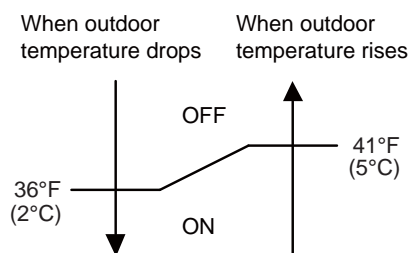

- * When the compressor stops, Base heater is OFF.
- * When the outdoor fan motor stops, Base heater is OFF.
- * In the cooling mode, Base heater is OFF.
- * After defrost, it will turn OFF the heater (Comp Accumulated operation time) after 15 minutes.

21. HEAT INSULATION CONDITION (BUILDING INSULATION)

This setting can make the room temperature control more suitable for homes or buildings with high insulation (Function Number 95).

When the thermo sensor is turned ON it controls the compressor frequency at initial start to prevent overshoot in heating or cooling.

22. THERMO CONTROL (FOR INDOOR UNIT SENSOR)

When room temperature is controlled by the Indoor unit sensor, compressor operation is as shown in Fig. 11 and 12 .

But, adjustment is possible by the room temperature correction function setting. (Function Number 30 or 31)

(Fig. 11 : For cooling operation)

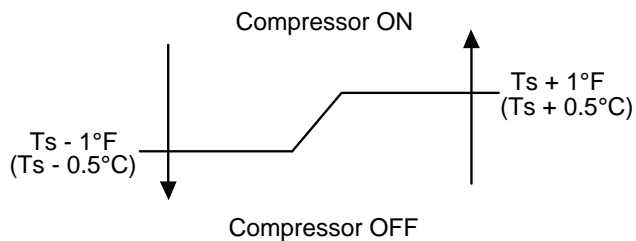

(Fig. 12 : For heating operation)

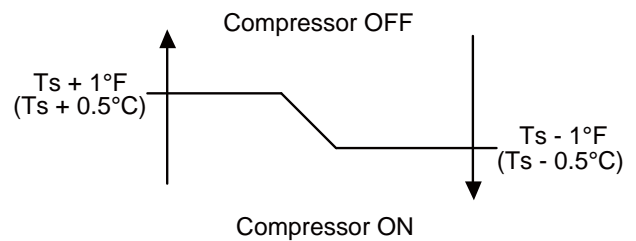

• T_s : Setting temperature

23. THERMO CONTROL (FOR WIRED REMOTE SENSOR)

When room temperature is controlled by the Wired remote sensor, compressor operation is as shown in Fig. 13 and 14 .

But, adjustment is possible by the room temperature correction function setting. (Function Number 92 or 93)

(Fig. 13 : For cooling operation)

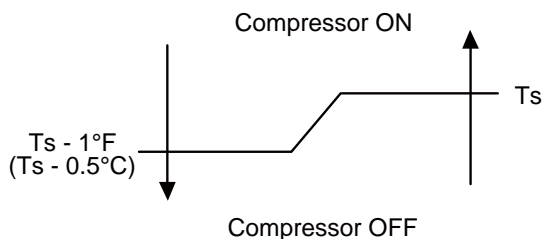

(Fig. 14 : For heating operation)

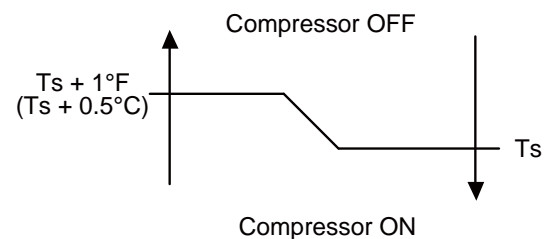

• T_s : Setting temperature

24. DEFROST OPERATION CONTROL

1. CONDITION OF STARTING THE DEFROST OPERATION

The defrost operation starts as shown in the following Table 18, 19, 20 and 21.

(Table 18 : Condition of 1st defrost operation)

1st defrost after starting operation	Compressor integrating operation time		
	Less than 17 minutes	More than 17 minutes	More than 57 minutes
	Does not operate	$T_n \leq 15.8^\circ\text{F}(-9^\circ\text{C})$ and $T_a - T_n \geq 41^\circ\text{F}(5^\circ\text{C})$ (and after 5 minutes, in the $41^\circ\text{F}(5^\circ\text{C})$)	$T_n \leq 23^\circ\text{F}(-5^\circ\text{C})$ (and after 5 minutes, if the $23^\circ\text{F}(-5^\circ\text{C})$)

T_n : Outdoor heat exchanger temperature.
 T_a : Outdoor temperature.

(Table 19 : Condition of 2nd defrost operation)

From 2nd and later defrost after starting operation	Compressor integrating operation time	
	Less than 35 minutes	More than 35 minutes
	Does not operate	① $T_n \leq -77^\circ\text{F}(-25^\circ\text{C})$ ② $T_n - T_{n10} < -41^\circ\text{F}(5^\circ\text{C})$ ($T_n \leq -42.8^\circ\text{F}(6^\circ\text{C})$) ③ $T_n - T_{nb} < -35.6^\circ\text{F}(2^\circ\text{C})$ ($T_n \leq -42.8^\circ\text{F}(6^\circ\text{C})$)

T_{n10} : Temperature of continuous operation at 10 minutes.
 T_{nb} : Back 5 minutes temperature.

(Table 20 : Condition of Integrating defrost operation)

Integrating defrost	Compressor integrating operation time	
	More than 210 minutes (For long continuous operation)	More than 210 minutes (For long continuous operation)
	$T_n \leq 26.6^\circ\text{F}(-3^\circ\text{C})$ (and after 30 minutes, if the $26.6^\circ\text{F}(-3^\circ\text{C})$)	$T_n \leq 23^\circ\text{F}(-5^\circ\text{C})$ (and after 5 minutes, if the $23^\circ\text{F}(-5^\circ\text{C})$)

(Table 21 : Condition of Integrating (OFF count) defrost operation)

Integrating defrost (OFF count defrost)	Compressor integrating operation time
	Less than 10 minutes* (For intermittent operation)
	OFF count of the compressor : 40 times

*If the compressor continuous operation time is less than 10 minutes, the OFF number of the compressor is counted.
 If any defrost operated, the compressor OFF count is cleared.

2. CONDITION OF THE DEFROST OPERATION COMPLETION

Defrost operation is released when the conditions becomes as shown in Table 22.

(Table 22 : Condition of defrost release)

Release Condition
Outdoor heat exchanger temperature is higher than $55.4^\circ\text{F}(13^\circ\text{C})$ or Compressor operation time has passed 15 minutes.

3. Defrost Flow Chart

The defrosting shall proceed by the integrating operation time, outdoor temperature and outdoor heat exchanger temperature as follows.

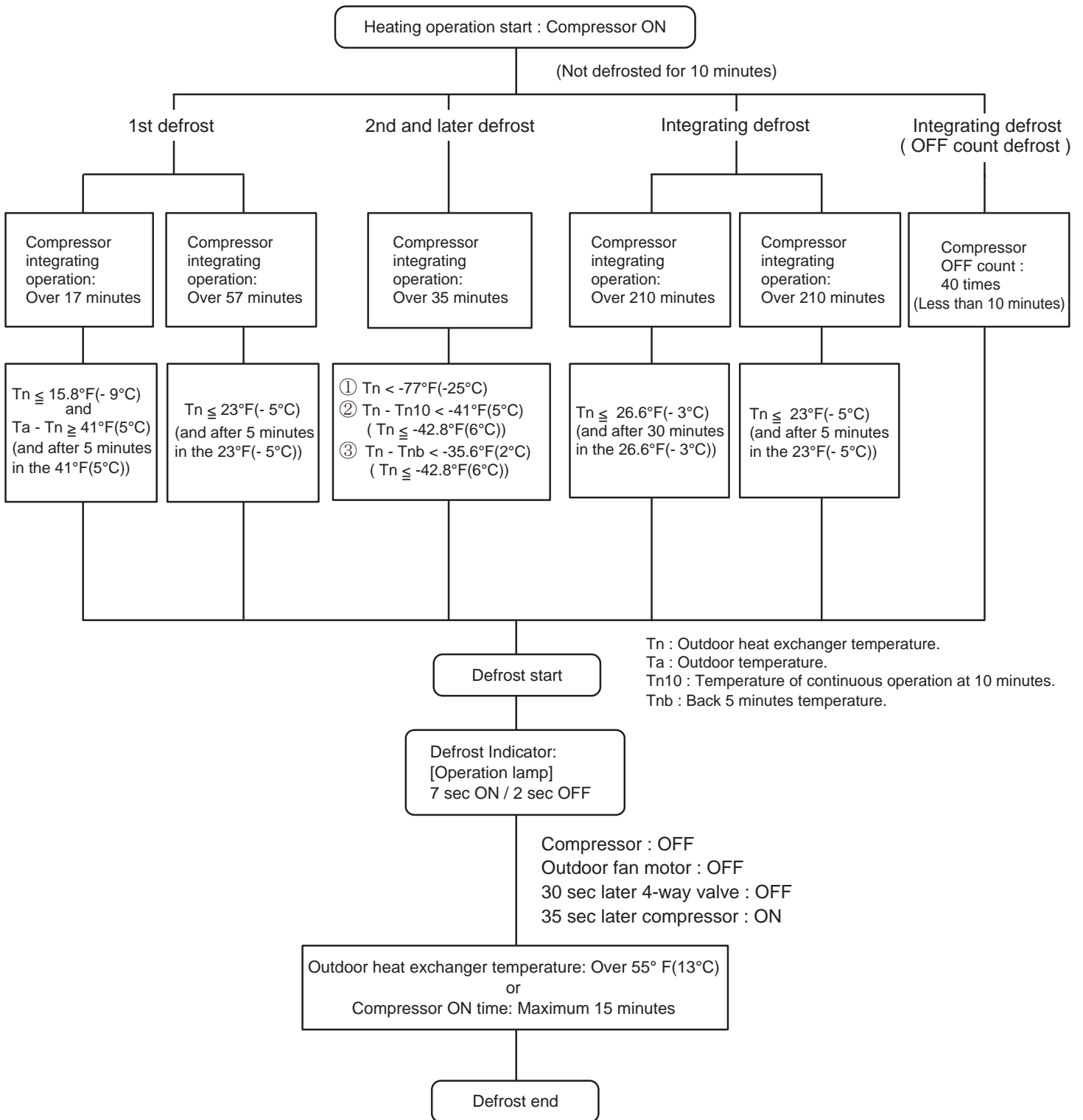

25. OFF DEFROST OPERATION CONTROL

When operation stops in the [Heating operation] mode, if frost is adhered to the outdoor unit heat exchanger, the defrost operation will proceed automatically.

In this time, if indoor unit operation lamp flashes slowly (7 sec ON / 2 sec OFF), the outdoor unit will allow the heat exchanger to defrost, and then stop.

1. OFF DEFROST OPERATION CONDITION

In heating operation, the outdoor heat exchanger temperature is less than 24.8°F(-4°C), and compressor operation integrating time lasts for more than 30 minutes.

2. OFF DEFROST RELEASE CONDITION

OFF defrost operation is released when the conditions becomes as shown in Table 23.

(Table 23 : OFF Defrost Release Condition)

Release Condition
Outdoor heat exchanger temperature is higher than 55.4°F(13°C) or Compressor operation time has passed 10 minutes.

OFF Defrost Flow Chart

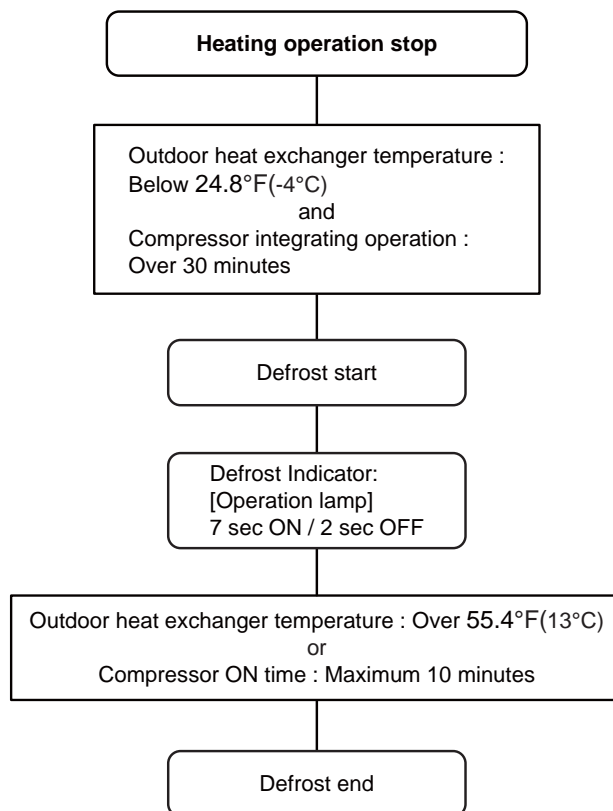

26. VARIOUS PROTECTIONS

1. DISCHARGE GAS TEMPERATURE OVERRISE PREVENTION CONTROL

The discharge gas thermo sensor (discharge thermistor : Outdoor side) will detect discharge gas temperature.

When the discharge temperature becomes higher than Temperature I , the compressor frequency is decreased 10rps, and it continues to decrease the frequency for 10rps every 120 seconds until the temperature becomes lower than Temperature II .

When the discharge temperature becomes lower than Temperature II , the control of the control of the compressor frequency is released.

When the discharge temperature becomes higher than Temperature III, the compressor is stopped and the indoor unit LED starts blinking.

(Table 24 : Discharge temperature over rise prevention control / Release temperature)

	Temperature I	Temperature II	Temperature III
AOU18 / 24RLXFWH	219.2°F (104°C)	213.8°F (101°C)	230°F (110°C)

2. CURRENT RELEASE CONTROL

The compressor frequency is controlled so that the outdoor unit input current does not exceeds the current limit value that was set up with the outdoor temperature.

The compressor frequency returns to the designated frequency of the indoor unit at the time when the frequency becomes lower than the release value.

(Table 25 : Current release operation value / Release value)

[Heating]

AOU18RLXFWH	
OT (Control / Release)	
10.0A/ 9.5A	62.6°F(17°C)
11.5A/ 11.0A	53.6°F(12°C)
13.0A/ 12.5A	41°F(5°C)
13.0A/ 12.5A	

OT : Outdoor Temperature

AOU24RLXFWH	
OT (Control / Release)	
11.0A/ 10.5A	62.6°F(17°C)
13.0A/ 12.5A	53.6°F(12°C)
15.0A/ 14.5A	41°F(5°C)
15.0A/ 14.5A	

OT : Outdoor Temperature

[Cooling]

AOU18RLXFWH	
OT (Control / Release)	
9.0A/ 8.5A	122°F(50°C)
10.0A/ 9.5A	114.8°F(46°C)
12.5A/ 12.0A	104°F(40°C)
12.5A/ 15.0A	53.6°F(12°C)
12.5A/ 15.0A	35.6°F(2°C)
12.5A/ 15.0A	

OT : Outdoor Temperature

AOU24RLXFWH	
OT (Control / Release)	
9.0A/ 8.5A	122°F(50°C)
10.0A/ 9.5A	114.8°F(46°C)
13.0A/ 12.5A	104°F(40°C)
14.5A/ 14.0A	53.6°F(12°C)
14.5A/ 14.0A	35.6°F(2°C)
14.5A/ 14.0A	

OT : Outdoor Temperature

3. ANTI-FREEZING CONTROL (Cooling and Dry mode)

The compressor frequency is decrease on cooling and dry mode when the indoor heat exchanger temperature sensor detects the temperature lower than Temperature I. Then, the anti-freezing control is released when it becomes higher than Temperature II.

(Table 26 : Anti-freezing protection operation / Release temperature)

Outdoor temperature	Temperature I	Temperature II
Over than 50°F(10°C) *1 or 53.6°F(12°C) *2	39.2°F (4°C)	44.6°F (7°C)
Less than 50°F(10°C) *1 or 53.6°F(12°C) *2		55.4°F (13°C)

*1. When the temperature rises.

*2. When the temperature drops.

4. COOLING PRESSURE OVERRISE PROTECTION

When the outdoor unit heat exchange sensor temperature rises to 152.6°F (67°C) or greater, the compressor and the outdoor fan motor are stopped and trouble display is performed.

5. HIGH TEMPERATURE RELEASE CONTROL (Heating mode)

On heating mode, the compressor frequency is controlled as following based on the detection value of the indoor heat exchanger temperature sensor.

[Control System]

Indoor heat exchange temperature

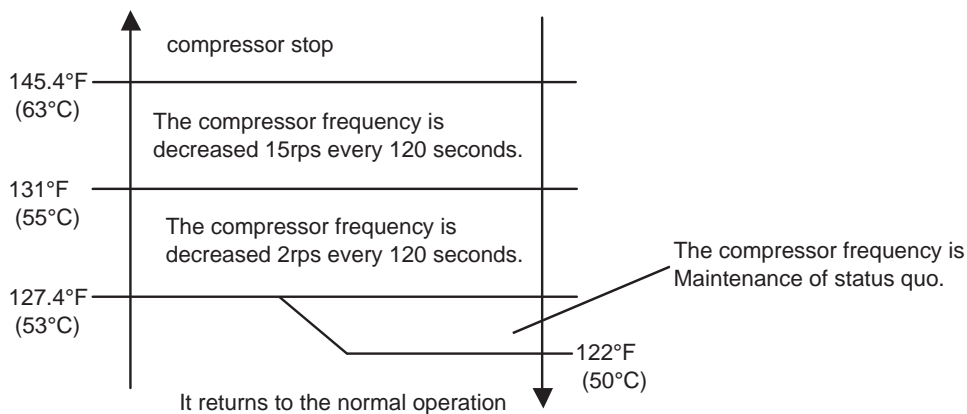

WALL MOUNTED type INVERTER

2 . TROUBLE SHOOTING

2-1 ERROR DISPLAY

2-1-1 INDOOR UNIT AND WIRED REMOTE CONTROLLER DISPLAY

Please refer the flashing pattern as follows.

Indoor Unit : ASU18RLF / 24RLF

The OPERATION, TIMER, ECONOMY lamps operate as follows according to the error contents.

Error Contents	Indoor Unit Display			Wired Remote Controller Display	Trouble shooting
	Operation (Green)	Timer (Orange)	Economy (Green)		
Serial Communication Error	1 times	1 times	Continuous	11	1,2
Wired Remote Controller Communication Error	1 times	2 times	Continuous	12	3
Indoor Unit Model Information Error EEPROM Access Abnormal	3 times	2 times	Continuous	32	4
Manual Auto Switch Error	3 times	5 times	Continuous	35	5
Indoor Room Thermistor Error	4 times	1 times	Continuous	41	6
Indoor Heat Ex. Thermistor Error	4 times	2 times	Continuous	42	7
Indoor Unit Fan Motor Error	5 times	1 times	Continuous	51	8
A. F. Voltage Error	6 times	4 times	Continuous	64	9
IPM Error	6 times	5 times	Continuous	65	10
Discharge Thermistor Error	7 times	1 times	Continuous	71	11
Compressor Thermistor Error	7 times	2 times	Continuous	72	12
Heat Ex. Liquid Outlet Thermistor Error	7 times	3 times	Continuous	73	13
Outdoor Thermistor Error	7 times	4 times	Continuous	74	14
Current Sensor Error	8 times	4 times	Continuous	84	15
High Pressure Switch Error	8 times	6 times	Continuous	86	16
Over Current Error	9 times	4 times	Continuous	94	17
Compressor Control Error	9 times	5 times	Continuous	95	18
Outdoor Unit Fan Motor Error	9 times	7 times	Continuous	97	19
4 Way Valve Error	9 times	9 times	Continuous	99	20
Discharge Temp. Error	10 times	1 times	Continuous	A1	21
Compressor Temp. Error	10 times	3 times	Continuous	A3	22

2-1-2 WIRED REMOTE CONTROLLER DISPLAY (OPTION)

1. SELF - DIAGNOSIS

When "EE" in Temperature Display is displayed, inspection of the air conditioning system is necessary. Please consult authorized service personnel.

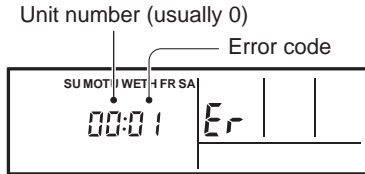

ex. Self-diagnosis check

2. ERROR CODE HISTORY DISPLAY

Up to 16 memorized error codes may be displayed for the indoor unit connected to the remote controller.

1. Stop the air conditioner operation.

2. Press the SET TEMPERATURE buttons ∇ , \blacktriangle simultaneously for 3 seconds or more to start the self-diagnosis.

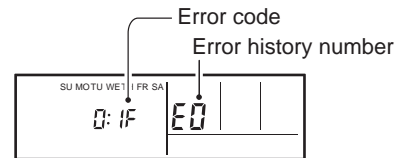
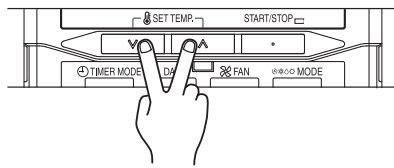

3. Press the SET TEMPERATURE button to select the error history number.

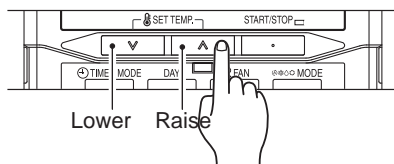

0 ↔ 1 ↔ 2 ↔ 3 ↔ 4 ↔ 5 ↔ 6 ↔ 7
F ↔ E ↔ d ↔ c ↔ b ↔ A ↔ 9 ↔ 8

4. Press the SET TEMPERATURE buttons ∇ , \blacktriangle simultaneously for 3 seconds or more or there is no key input for 60 seconds to stop the display.

2-2 TROUBLE SHOOTING WITH ERROR CODE

Trouble shooting 1 OUTDOOR UNIT Error Method: Serial Communication Error (Serial Reverse Transfer Error)	Indicate or Display: Outdoor Unit : No indication Indoor Unit : Operation lamp: 1 times Flash, Timer lamp: 1 times Flash Economy lamp: Continuous flash. ERROR CODE : [E : 11]
---	--

Detective Actuators: Outdoor unit Main PCB Outdoor unit Fan motor	Detective details: When the indoor unit cannot receive the serial signal from Outdoor unit more than 2 minutes after power ON, or the indoor unit cannot receive the serial signal more than 15 seconds during normal operation.
--	--

Forecast of Cause:

1. Connection failure 2. External cause 3. Main PCB failure 4. Active filter module failure
 5. Transistor PCB (IPM) failure 6. Filter PCB failure 7. Outdoor unit Fan motor failure

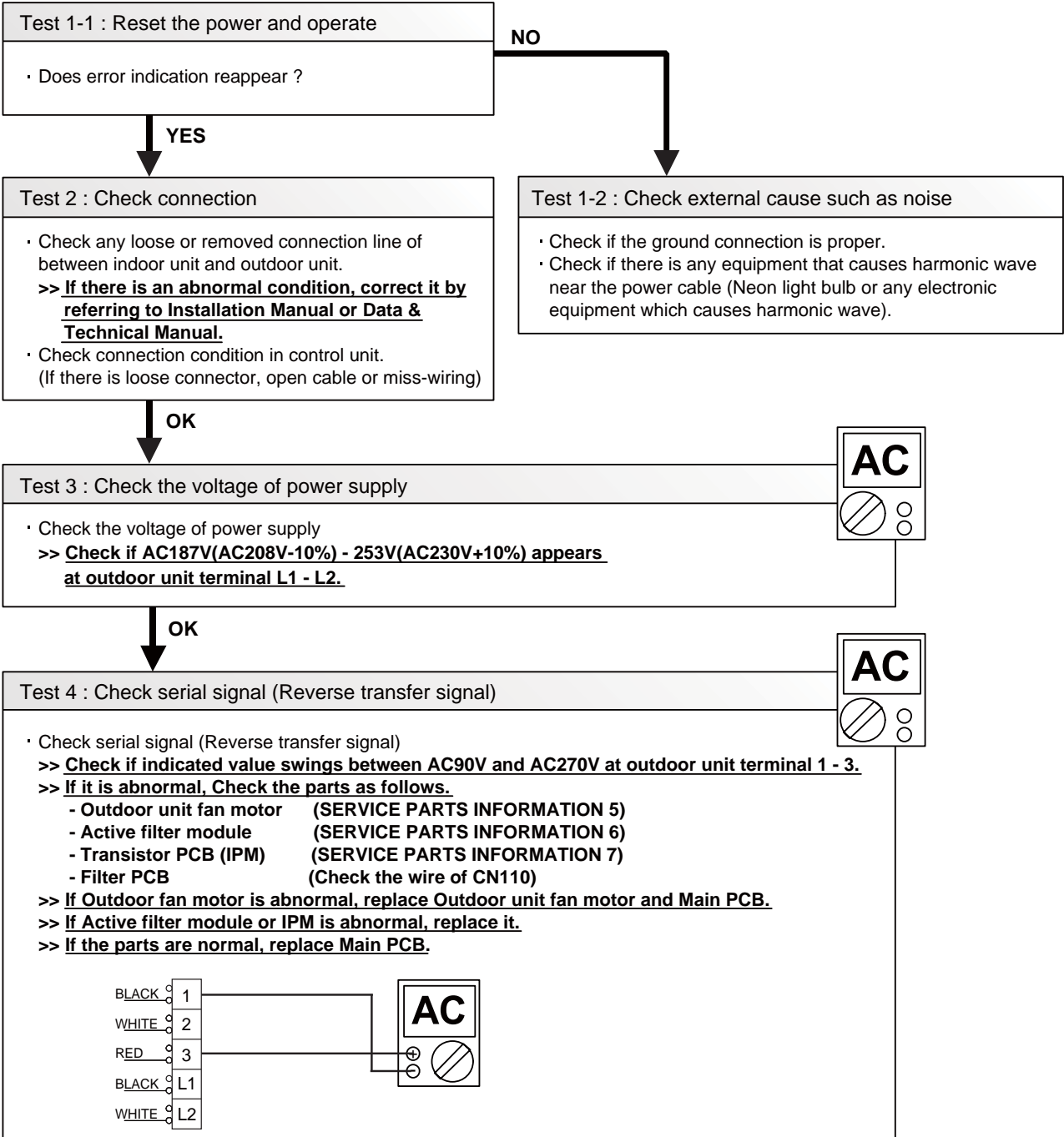

Trouble shooting 2 INDOOR UNIT Error Method: Serial Communication Error (Serial Forward Transfer Error)	Indicate or Display: Outdoor Unit : No indication Indoor Unit : Operation lamp: 1 times Flash, Timer lamp: 1 times Flash Economy lamp: Continuous flash. ERROR CODE : [E : 11]
--	--

Detective Actuators: Indoor unit Controller PCB	Detective details: When the outdoor unit cannot properly receive the serial signal from indoor unit for 10 seconds or more.
---	---

Forecast of Cause:
1. Connection failure 2. External cause 3. Controller PCB failure

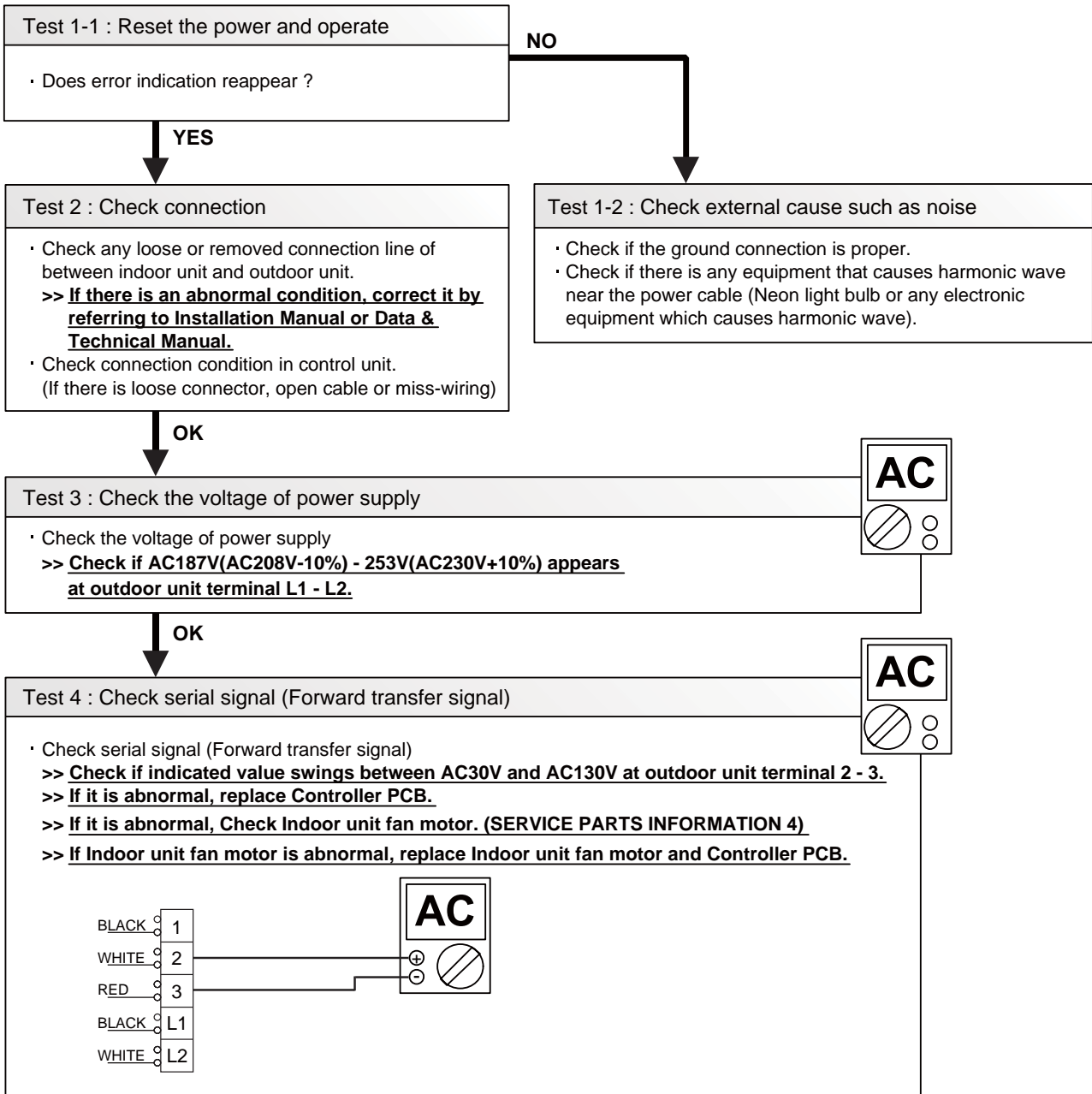

Trouble shooting 3 INDOOR UNIT Error Method: Wired Remote Controller Communication Error	Indicate or Display: Outdoor Unit : No indication Indoor Unit : Operation lamp: 1 times Flash, Timer lamp: 2 times Flash Economy lamp: Continuous flash. ERROR CODE : [E : 12]
---	--

Detective Actuators: Indoor unit Controller PCB Wired Remote Controller (Option)	Detective details: When the indoor unit cannot properly receive the signal from Wired Remote Controller for 1 minute or more.
---	--

Forecast of Cause:
1. Connection failure 2. Wired Remote Controller failure 3. Controller PCB failure

Test 1 : Check the connection of terminal

Check & correct the followings.

- Check the connection of terminal between Wired Remote Controller and indoor unit, and check if there is a disconnection of the cable.



Test 2 : Check Wired Remote Controller and Controller PCB

- Check Voltage at CN6 (terminal 1-3) of Controller PCB.
(Power supply to Remote Control)

>> If it is DC12V, Remote Control is failure. (Controller PCB is normal) >> Replace Remote Control
>> If it is DC 0V, Controller PCB is failure. (Check Remote Control once again) >> Replace Controller PCB



Trouble shooting 4 INDOOR UNIT Error Method: Indoor Unit Model Information Error EEPROM Access Abnormal	Indicate or Display: Outdoor Unit : No indication Indoor Unit : Operation lamp: 3 times Flash, Timer lamp: 2 times Flash Economy lamp: Continuous flash. ERROR CODE : [E : 32]
--	--

Detective Actuators: Indoor unit Controller PCB	Detective details: When power is on and there is some below case. 1. When model information of EEPROM is incorrect. 2. When the access to EEPROM failed.
---	--

Forecast of Cause:
1. External cause 2. Defective connection of electric components 3. Controller PCB failure

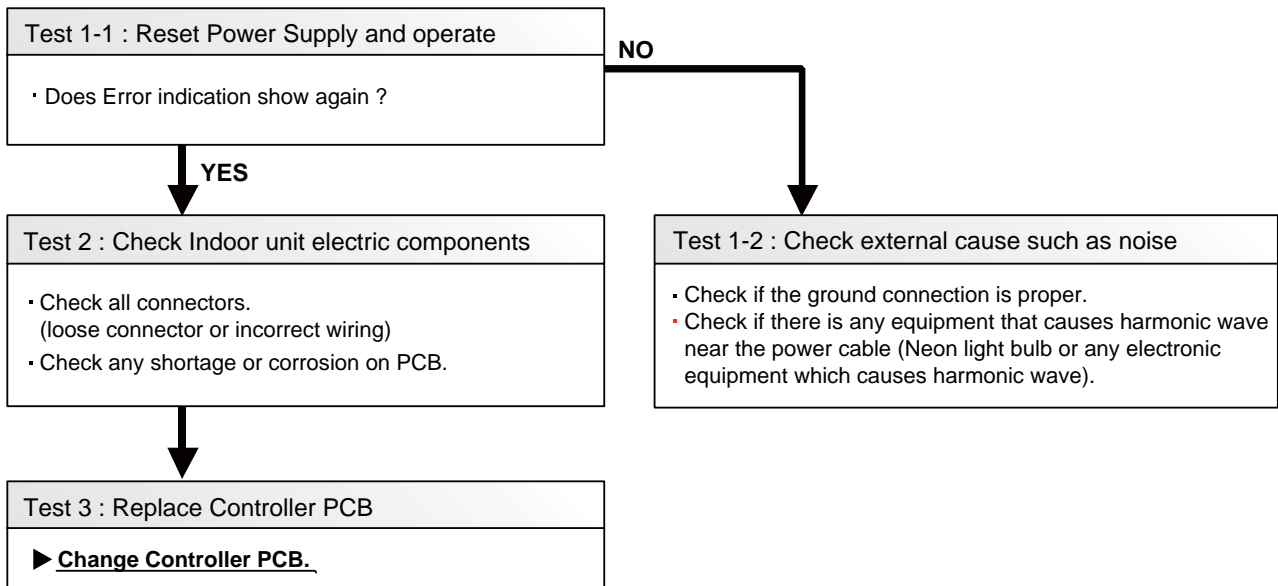



Note : EEPROM
EEPROM(Electronically Erasable and Programmable Read Only Memory) is a non-volatile memory which keeps memorized information even if power is turned off. It can change the contents electronically.
To change the contents, it uses higher voltage than normal, and it can not change a partial contents. (Rewriting shall be done upon erasing the all contents.)
There is a limit in a number of rewriting.

<p>Trouble shooting 5 <u>INDOOR UNIT Error Method:</u> Manual Auto Switch Error</p>	<p><u>Indicate or Display:</u> Outdoor Unit : No indication Indoor Unit : Operation lamp: 3 times Flash, Timer lamp: 5 times Flash Economy lamp: Continuous flash. ERROR CODE : [E : 35]</p>
--	--

<p><u>Detective Actuators:</u> Indoor Unit Controller PCB Indicator PCB Manual Auto Switch</p>	<p><u>Detective details:</u> When the Manual Auto Switch becomes ON for consecutive 60 or more seconds.</p>
--	---

<p><u>Forecast of Cause:</u> 1. Manual Auto Switch failure 2. Controller PCB and Indicator PCB failure</p>

<p>Test 1 : Check the Manual Auto Switch</p>	
<ul style="list-style-type: none"> · Check if Manual Auto Switch is kept pressed. · Check ON/OFF switching operation by using a meter. <p>>> <u>If Manual Auto Switch is disabled (on/off switching), replace it.</u></p>	



<p>Test 2 : Replace Controller PCB and Indicator PCB</p>
<p>▶ <u>If Test 1 do not improve the symptom, replace Controller PCB and Indicator PCB and execute the check operation again.</u></p>

Trouble shooting 6 INDOOR UNIT Error Method: Indoor Room Thermistor Error	Indicate or Display: Outdoor Unit : No indication Indoor Unit : Operation lamp: 4 times Flash, Timer lamp: 1 times Flash Economy lamp: Continuous flash. ERROR CODE : [E : 41]
--	--

Detective Actuators: Indoor unit Controller PCB Circuit Indoor Temperature Thermistor	Detective details: Indoor unit thermistor is open or short is detected always.
--	--

Forecast of Cause:
1. Connector failure connection 2. Thermistor failure 3. Controller PCB failure

Test 1 : Check connection of Connector

- Check if connector is loose or removed
- Check erroneous connection
- Check if thermistor cable is open

>>Reset Power when reinstalling due to removed connector or incorrect wiring.



Ω

Test 2 : Remove connector and check Thermistor resistance value

Thermistor Characteristics (Rough value)

Temperature (°C)	0	5	10	15	20	25	30	35
Temperature (°F)	32	41	50	59	68	77	86	95
Resistance value (k Ω)	33.6	25.9	20.2	15.8	12.5	10.0	8.0	6.5

Temperature (°C)	40	45	50
Temperature (°F)	104	113	122
Resistance value (k Ω)	5.3	4.3	3.6

► If Thermistor is either open or shorted, replace it and reset the power.



DC

Test 3 : Check voltage of Controller PCB (DC5.0V)

Make sure circuit diagram of each indoor unit and check terminal voltage at Thermistor (DC5.0V)

The diagram shows two connector types: CN3 and CN1. CN3 has three terminals: 1 (RED), 2 (WHITE), and 3 (BLACK). It is connected to a thermistor labeled 'THERMISTOR (PIPE TEMP.)'. CN1 has two terminals: 1 (BLACK) and 2 (BLACK). It is connected to a thermistor labeled 'THERMISTOR (ROOM TEMP.)'.

► If the voltage does not appear, replace Controller PCB and execute the check operation again.

Trouble shooting 7 INDOOR UNIT Error Method: Indoor Heat Ex. Thermistor Error	Indicate or Display: Outdoor Unit : No indication Indoor Unit : Operation lamp: 4 times Flash, Timer lamp: 2 times Flash Economy lamp: Continuous flash. ERROR CODE : [E : 42]
--	--

Detective Actuators: Indoor Unit Controller PCB Heat Exchanger (MID) Thermistor	Detective details: Indoor unit thermistor is open or short is detected always.
--	--

Forecast of Cause:
1. Connector failure connection 2. Thermistor failure 3. Controller PCB failure

Test 1 : Check connection of Connector

- Check if connector is loose or removed
- Check erroneous connection
- Check if thermistor cable is open

>>Reset Power when reinstalling due to removed connector or incorrect wiring.



Test 2 : Remove connector and check Thermistor resistance value

Thermistor Characteristics (Rough value)

Temperature (°C)	0	5	10	15	20	25	30	35
Temperature (°F)	32	41	50	59	68	77	86	95
Resistance value (kΩ)	176.0	134.2	103.3	80.3	62.9	49.7	39.6	31.7

Temperature (°C)	40	45	50
Temperature (°F)	104	113	122
Resistance value (kΩ)	25.6	20.9	17.1

▶ If Thermistor is either open or shorted, replace it and reset the power.



Test 3 : Check voltage of Controller PCB (DC5.0V)

Make sure circuit diagram of each indoor unit and check terminal voltage at Thermistor (DC5.0V)

The diagram shows two connector types: CN3 and CN1. CN3 has four terminals: 1-1 (RED), 1-2 (WHITE), 2-2 (BLACK), and 3-3 (BLACK). CN1 has two terminals: 1-1 (BLACK) and 2-2 (BLACK). Each terminal pair is connected to a thermistor symbol. The thermistor connected to CN3 terminals 1-1 and 2-2 is labeled 'THERMISTOR (PIPE TEMP.)'. The thermistor connected to CN1 terminals 1-1 and 2-2 is labeled 'THERMISTOR (ROOM TEMP.)'.

▶ If the voltage does not appear, replace Controller PCB and execute the check operation again.

Trouble shooting 8 <u>INDOOR UNIT Error Method:</u> Indoor Unit Fan Motor Error	<u>Indicate or Display:</u> Outdoor Unit : No indication Indoor Unit : Operation lamp: 5 times Flash, Timer lamp: 1 times Flash Economy lamp: Continuous flash. ERROR CODE : [E : 51]
--	---

<u>Detective Actuators:</u> Indoor unit Controller PCB Indoor unit Fan motor	<u>Detective details:</u> When the condition that actual frequency of Indoor Fan is below 1/3 of target frequency is continued more than 56 seconds.
---	--

<u>Forecast of Cause:</u> 1. Fan rotation failure 2. Fan motor winding open 3. Motor protection by surrounding temperature rise 4. Control PCB failure 5. Indoor unit fan motor failure
--

Test 1 : Check rotation of Fan

- Rotate the fan by hand when operation is off.
(Check if fan is caught, dropped off or locked motor)

>>If Fan or Bearing is abnormal, replace it.



Test 2 : Check ambient temp. around motor

- Check excessively high temperature around the motor.
(If there is any surrounding equipment that causes heat)

>>Upon the temperature coming down, restart operation.



Test 3 : Check Indoor unit fan motor

- Check Indoor unit fan motor. **(SERVICE PARTS INFORMATION 4)**

>>If Indoor unit fan motor is abnormal, replace Indoor unit fan motor.



Test 4 : Replace Controller PCB

▶ If Test 1- 3 do not improve the symptom, replace Controller PCB.

Trouble shooting 9 <u>OUTDOOR UNIT Error Method:</u> A.F Voltage Error	<u>Indicate or Display:</u> Outdoor Unit : No indication Indoor Unit : Operation lamp: 6 times Flash, Timer lamp: 4 times Flash Economy lamp: Continuous flash. ERROR CODE : [E : 64]
---	---

<u>Detective Actuators:</u> Outdoor unit Main PCB Active filter module	<u>Detective details:</u> When inverter input DC voltage is higher than 425V or lower than 80V. When a momentary power cut off occurred on low voltage.
---	--

Forecast of Cause:
1. External cause 2. Connector connection failure 3. Main PCB failure 4. Active filter module failure

Test 1 : Check external cause at Indoor and Outdoor (Voltage drop or Noise)

- Instant drop : Check if there is a large load electric apparatus in the same circuit.
- Momentary power failure : Check if there is a defective contact or leak current in the power supply circuit.
- Noise : Check if there is any equipment causing harmonic wave near electric line. (Neon bulb or electric equipment that may cause harmonic wave)
Check the complete insulation of grounding.



Test 2 : Check connection of Connector

- Check if connector is removed.
- Check erroneous connection.
- Check if cable is open.

>>Upon correcting the removed connector or miss-wiring, reset the power.



Test 3 : Check Active filter module

- Check Active filter module. (**SERVICE PARTS INFORMATION 6**)

>>If Active filter module is abnormal, replace it.



Test 4 : Replace Main PCB

▶ If Test 1 - 3 do not improve the symptom, change Main PCB.

Trouble shooting 10 <u>OUTDOOR UNIT Error Method:</u> IPM Error	<u>Indicate or Display:</u> Outdoor Unit : No indication Indoor Unit : Operation lamp: 6 times Flash, Timer lamp: 5 times Flash Economy lamp: Continuous flash. ERROR CODE : [E : 65]
--	---

<u>Detective Actuators:</u> Outdoor unit Main PCB Compressor	<u>Detective details:</u> ① When more than normal operating current to IPM in Main PCB flows, the compressor stops. ② After the compressor restarts, if the same operation is repeated within 40sec, the compressor stops again. ③ If ① and ② repeats 5 times, the compressor stops permanently.
---	--

<u>Forecast of Cause:</u> 1. Defective connection of electric components 2. Outdoor Fan Operation failure 3. Outdoor Heat Exchanger clogged 4. Compressor failure 5. Transistor PCB failure 6. Main PCB failure
--

Test 1 : Check connections of Outdoor Unit Electrical Components
<ul style="list-style-type: none"> · Check if the terminal connection is loose. · Check if connector is removed. · Check erroneous connection. · Check if cable is open. >> <u>Upon correcting the removed connector or miss-wiring, reset the power.</u>



Test 2 : Check Outdoor Fan, Heat Exchanger
<ul style="list-style-type: none"> · Is there anything obstructing the air distribution circuit? · Is there any clogging of Outdoor Heat Exchanger? · Is the Fan rotating by hand when operation is off ? >> <u>If the Fan Motor is locked, replace it.</u>



Test 3 : Check Outdoor Fan
<ul style="list-style-type: none"> · Check Outdoor Fan Motor. (Refer to Trouble shooting 19) >> <u>If the Fan Motor is failure, replace it.</u>



Test 4 : Check Compressor
<ul style="list-style-type: none"> · Check Compressor.(SERVICE PARTS INFORMATION 2)



Test 5 : Check Transistor PCB
<ul style="list-style-type: none"> · Check Transistor PCB.(SERVICE PARTS INFORMATION 7)



Test 6 : Replace Main PCB
▶ <u>If Test 1 - 5 do not improve the symptom, change Main PCB.</u>

Trouble shooting 11 OUTDOOR UNIT Error Method: Discharge Thermistor Error	Indicate or Display: Outdoor Unit : No indication Indoor Unit : Operation lamp: 7 times Flash, Timer lamp: 1 times Flash Economy lamp: Continuous flash. ERROR CODE : [E : 71]
--	--

Detective Actuators: Outdoor Unit Main PCB Discharge Pipe Temperature Thermistor	Detective details: When Discharge Pipe Temperature Thermistor open or short-circuit is detected at power ON or while running the compressor.
---	--

Forecast of Cause:
1. Connector connection failure 2. Thermistor failure 3. Main PCB failure

Test 1 : Check connection of connector

- Check if connector is removed.
- Check if connector is erroneous connection.
- Check if thermistor cable is open.

>> Upon correcting the removed connector or miss-wiring, reset the power.



Test 2 : Remove connector and check thermistor resistance value

Thermistor characteristics (Approx. value)

Temperature (°C)	0	5	10	15	20	30	40	50	60
Temperature (°F)	32	41	50	59	68	86	104	122	140
Resistance value (kΩ)	175.7	134.9	104.6	81.8	64.5	41.1	26.9	18.1	12.5

Temperature (°C)	70	80	90	100	120
Temperature (°F)	158	176	194	212	248
Resistance value (kΩ)	8.8	6.3	4.6	3.4	2.0

► If Thermistor is either open or shorted, replace it and reset the power.



Test 3 : Check voltage of Main PCB (DC5.0V)

Make sure circuit diagram of outdoor unit and check terminal voltage at thermistor (DC5.0V)

CN64	1 1 2 2 3 3	BROWN BROWN		THERMISTOR (COMPRESSOR TEMP.)
CN62	1 1 2 2 3 3	BLUE BLUE		THERMISTOR (OUTDOOR TEMP.)
CN65	1 1 2 2 3 3	BLACK BLACK		THERMISTOR (PIPE TEMP.)
CN63	1 1 2 2 3 3	BROWN BROWN		THERMISTOR (DISCHARGE TEMP.)

► If the voltage does not appear, replace Main PCB.

Trouble shooting 12 <u>OUTDOOR UNIT Error Method:</u> Compressor Thermistor Error	<u>Indicate or Display:</u> Outdoor Unit : No indication Indoor Unit : Operation lamp: 7 times Flash, Timer lamp: 2 times Flash Economy lamp: Continuous flash. ERROR CODE : [E : 72]
--	---

<u>Detective Actuators:</u> Outdoor Unit Main PCB Compressor Temperature Thermistor	<u>Detective details:</u> When Compressor Temperature Thermistor open or short-circuit is detected at power ON or while running the compressor.
--	---

Forecast of Cause:
1. Connector connection failure 2. Thermistor failure 3. Main PCB failure

Test 1 : Check connection of connector

- Check if connector is removed.
- Check if connector is erroneous connection.
- Check if thermistor cable is open.

>> Upon correcting the removed connector or miss-wiring, reset the power.



Test 2 : Remove connector and check thermistor resistance value Ω

Thermistor characteristics (Approx. value)

Temperature (°C)	0	5	10	15	20	30	40	50	60
Temperature (°F)	32	41	50	59	68	86	104	122	140
Resistance value (kΩ)	168.6	129.8	100.9	79.1	62.6	40.0	26.3	17.8	12.3

Temperature (°C)	70	80	90	100	120
Temperature (°F)	158	176	194	212	248
Resistance value (kΩ)	8.7	6.3	4.6	3.4	2.0

▶ If Thermistor is either open or shorted, replace it and reset the power.



Test 3 : Check voltage of Main PCB (DC5.0V) DC

Make sure circuit diagram of outdoor unit and check terminal voltage at thermistor (DC5.0V)

▶ If the voltage does not appear, replace Main PCB.

Trouble shooting 13 OUTDOOR UNIT Error Method: Heat Ex. Liquid Outlet Thermistor Error	Indicate or Display: Outdoor Unit : No indication Indoor Unit : Operation lamp: 7 times Flash, Timer lamp: 3 times Flash Economy lamp: Continuous flash. ERROR CODE : [E : 73]
---	--

Detective Actuators: Outdoor Unit Main PCB Heat Exchanger Temperature Thermistor	Detective details: When Heat Exchanger Temperature Thermistor (Out) open or short-circuit is detected at power ON or while running the compressor.
---	--

Forecast of Cause:
1. Connector connection failure 2. Thermistor failure 3. Main PCB failure

Test 1 : Check connection of connector

- Check if connector is removed.
- Check if connector is erroneous connection.
- Check if thermistor cable is open.

>> Upon correcting the removed connector or miss-wiring, reset the power.

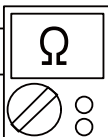

Test 2 : Remove connector and check thermistor resistance value 

Thermistor characteristics (Approx. value)

Temperature (°C)	-10	-5	0	5	10	15	20	25	30	35
Temperature (°F)	14	23	32	41	50	59	68	77	86	95
Resistance value (kΩ)	27.8	21.0	16.1	12.4	9.6	7.6	6.0	4.8	3.8	3.1

► If Thermistor is either open or shorted, replace it and reset the power.



Test 3 : Check voltage of Main PCB (DC5.0V) 

Make sure circuit diagram of outdoor unit and check terminal voltage at thermistor (DC5.0V)

CN64
1 1 BROWN
2 2 BROWN
3 3
THERMISTOR (COMPRESSOR TEMP.)

CN62
1 1 BLUE
2 2 BLUE
3 3
THERMISTOR (OUTDOOR TEMP.)

CN65
1 1 BLACK
2 2 BLACK
3 3
THERMISTOR (PIPE TEMP.)

CN63
1 1 BROWN
2 2 BROWN
3 3
THERMISTOR (DISCHARGE TEMP.)

► If the voltage does not appear, replace Main PCB.

Trouble shooting 14 <u>OUTDOOR UNIT Error Method:</u> Outdoor Thermistor Error	<u>Indicate or Display:</u> Outdoor Unit : No indication Indoor Unit : Operation lamp: 7 times Flash, Timer lamp: 4 times Flash Economy lamp: Continuous flash. ERROR CODE : [E : 74]
---	---

<u>Detective Actuators:</u> Outdoor Unit Main PCB Outdoor Temperature Thermistor	<u>Detective details:</u> When Outdoor Temperature Thermistor open or short-circuit is detected at power ON or while running the compressor.
---	--

Forecast of Cause:
 1. Connector connection failure 2. Thermistor failure 3. Main PCB failure

Test 1 : Check connection of connector

- Check if connector is removed.
- Check if connector is erroneous connection.
- Check if thermistor cable is open.

>> Upon correcting the removed connector or miss-wiring, reset the power.



Test 2 : Remove connector and check thermistor resistance value										
Thermistor characteristics (Approx. value)										
Temperature (°C)	-20	-10	-5	0	5	10	15	20		
Temperature (°F)	-4	14	23	32	41	50	59	68		
Resistance value (kΩ)	115.2	62.3	46.6	35.2	26.9	20.7	16.1	12.6		
Temperature (°C)	30	40	50	60	70					
Temperature (°F)	86	104	122	140	158					
Resistance value (kΩ)	8.0	5.2	3.5	2.4	1.6					
<p>► <u>If Thermistor is either open or shorted, replace it and reset the power.</u></p>										



Test 3 : Check voltage of Main PCB (DC5.0V)										
Make sure circuit diagram of outdoor unit and check terminal voltage at thermistor (DC5.0V)										
CN64	1	1	BROWN		THERMISTOR (COMPRESSOR TEMP.)					
	2	2	BROWN							
	3	3								
CN62	1	1	BLUE		THERMISTOR (OUTDOOR TEMP.)					
	2	2	BLUE							
	3	3								
CN65	1	1	BLACK		THERMISTOR (PIPE TEMP.)					
	2	2	BLACK							
	3	3								
CN63	1	1	BROWN		THERMISTOR (DISCHARGE TEMP.)					
	2	2	BROWN							
	3	3								
<p>► <u>If the voltage does not appear, replace Main PCB.</u></p>										

Trouble shooting 15 <u>OUTDOOR UNIT Error Method:</u> Current Sensor Error	<u>Indicate or Display:</u> Outdoor Unit : No indication Indoor Unit : Operation lamp: 8 times Flash, Timer lamp: 4 times Flash Economy lamp: Continuous flash. ERROR CODE : [E : 84]
---	---

<u>Detective Actuators:</u> Outdoor unit Main PCB	<u>Detective details:</u> When Input Current Sensor has detected 0A, while Inverter Compressor is operating at higher than 56rps, after 1 minute upon starting the Compressor. (Except during the defrost operation)
---	--

<u>Forecast of Cause:</u> 1. Defective connection of electric components 2. External cause 3. Main PCB failure
--

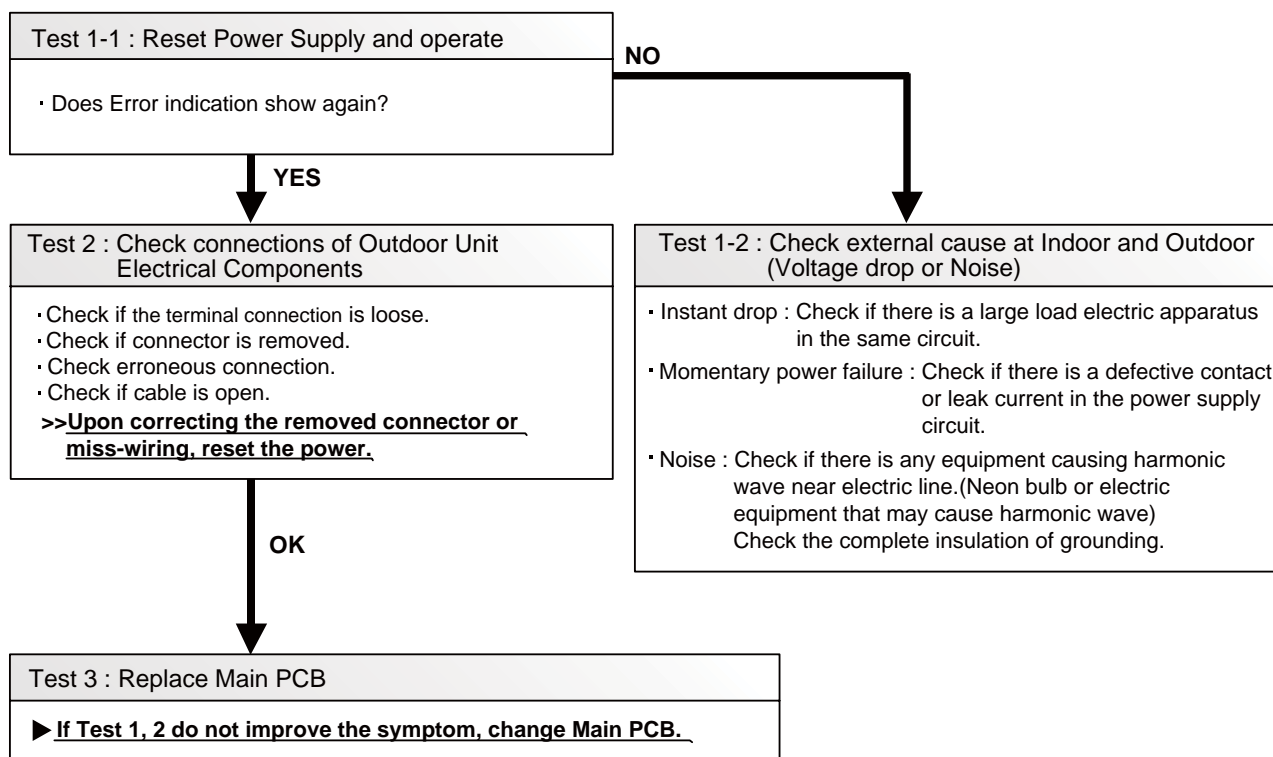

Trouble shooting 16 OUTDOOR UNIT Error Method: High Pressure Switch Error	Indicate or Display: Outdoor Unit : No indication Indoor Unit : Operation lamp: 8 times Flash, Timer lamp: 6 times Flash Economy lamp: Continuous flash. ERROR CODE : [E : 86]
--	--

Detective Actuators: Outdoor unit Main PCB High Pressure Switch	Detective details: When pressure switch open is detected in 10 seconds after the power is turned on.
--	--

Forecast of Cause: 1. High pressure switch connector disconnection, open 2. High pressure switch characteristics failure 3. Main PCB failure
--

Test 1 : Check the high pressure switch connection state
<ul style="list-style-type: none"> • Connector and wiring connection state check • Cable open check



Test 2 : Check the high pressure switch characteristics
<ul style="list-style-type: none"> • Switch characteristics check * For the characteristics of high pressure switch, refer to below.



Test 3 : Replace Main PCB
<ul style="list-style-type: none"> • Change Main PCB, and execute the check operation again.

• Type of contact

Pressure

• Characteristics of pressure switch (CN90)

	Pressure switch
Contact : Short ⇒ Open	609.2±14.5 PSI
Contact : Open ⇒ Short	464.1±21.8 PSI

Trouble shooting 17 <u>OUTDOOR UNIT Error Method:</u> Over Current Error	<u>Indicate or Display:</u> Outdoor Unit : No indication Indoor Unit : Operation lamp: 9 times Flash, Timer lamp: 4 times Flash Economy lamp: Continuous flash. ERROR CODE : [E : 94]
---	---

<u>Detective Actuators:</u> Outdoor unit Main PCB Compressor Transistor PCB	<u>Detective details:</u> • "Protection stop by over current generation after inverter compressor start processing completed" generated consecutively 10 times. * The number of generations is reset if the start-up of the compressor succeeds.
---	---

<u>Forecast of Cause:</u> 1. Outdoor unit fan operation defective, foreign matter on heat exchanger, excessive rise of ambient temperature 2. Main PCB 3. Inverter compressor failure (lock, winding short) 4. Transistor PCB (IPM) failure
--

Test 1 : Check the outdoor unit fan operation, heat exchanger, ambient temperature
<ul style="list-style-type: none"> • No obstructions in air passages? • Heat exchange fins clogged • Outdoor unit fan motor check • Ambient temperature not raised by the effect of other heat sources? • Discharged air not sucked in?

↓
OK

Test 2 : Check Transistor PCB (IPM)
<ul style="list-style-type: none"> • Check IPM. (SERVICE PARTS INFORMATION 7) >> <u>If IPM is abnormal, replace Transistor PCB.</u>

↓
OK

Test 3 : Replace Main PCB
<p style="text-align: center;">▶ <u>If Test 1,2 do not improve the symptom, change Main PCB.</u></p>

↓
OK

Test 4 : Replace Compressor
<p style="text-align: center;">▶ <u>If Test 3 do not improve the symptom, change Compressor.</u></p>

Trouble shooting 18 OUTDOOR UNIT Error Method: Compressor Control Error	Indicate or Display: Outdoor Unit : No indication Indoor Unit : Operation lamp: 9 times Flash, Timer lamp: 5 times Flash Economy lamp: Continuous flash. ERROR CODE : [E : 95]
--	--

Detective Actuators: Outdoor unit Main PCB Compressor Transistor PCB	Detective details: ① While running the compressor, if the detected rotor location is out of phase with actual rotor location more than 90°, the compressor stops. ② After the compressor restarts, if the same operation is repeated within 40sec, the compressor stops again. ③ If ① and ② repeats 5 times, the compressor stops permanently.
--	--

Forecast of Cause: 1. Defective connection of electric components 2. Main PCB failure 3. Compressor failure 4. Transistor PCB (IPM) failure
--

Test 1 : Check Noise from Compressor

- Turn on Power and check operation noise.

▶ **If an abnormal noise show, replace Compressor.**



Test 2 : Check connection of around the Compressor components

For Compressor Terminal, Main PCB

- Check if connector is removed.
- Check erroneous connection.
- Check if cable is open.

(Refer to **SERVICE PARTS INFORMATION 2**)

>>**Upon correcting the removed connector or miss-wiring, reset the power.**



Test 3 : Check Transistor PCB (IPM)

- Check IPM. (**SERVICE PARTS INFORMATION 7**)

>> **If IPM is abnormal, replace Transistor PCB.**



Test 4 : Replace Main PCB

▶ **If Test 1 - 3 do not improve the symptom, change Main PCB.**



Test 5 : Replace Compressor

▶ **If Test 4 do not improve the symptom, change Compressor.**

Trouble shooting 19 OUTDOOR UNIT Error Method: Outdoor Unit Fan Motor Error	Indicate or Display: Outdoor Unit : No indication Indoor Unit : Operation lamp: 9 times Flash, Timer lamp: 7 times Flash Economy lamp: Continuous flash. ERROR CODE : [E : 97]
--	--

Detective Actuators: Outdoor unit Main PCB Outdoor unit Fan motor	Detective details: ① When outdoor fan rotation speed is less than 100rpm in 20 seconds after fan motor starts, fan motor stops. ② After fan motor restarts, if the same operation within 60sec is repeated 3 times in a row, compressor and fan motor stops. ③ If ① and ② repeats 5 times in a row, compressor and fan motor stops permanently.
--	---

Forecast of Cause: 1. Fan rotation failure 2. Motor protection by surrounding temperature rise 3. Main PCB failure 4. Outdoor unit fan motor failure

Test 1 : Check rotation of Fan
• Rotate the fan by hand when operation is off. (Check if fan is caught, dropped off or locked motor) >>If Fan or Bearing is abnormal, replace it.

↓
OK

Test 2 : Check ambient temp. around motor
• Check excessively high temperature around the motor. (If there is any surrounding equipment that causes heat) >>Upon the temperature coming down, restart operation.

↓
OK

Test 3 : Check Outdoor unit fan motor
• Check Outdoor unit fan motor. (SERVICE PARTS INFORMATION 5) >>If Outdoor Fan Motor is abnormal, replace Outdoor fan motor and Main PCB.

↓
OK

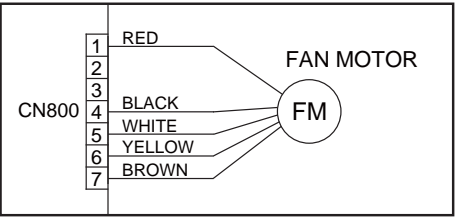
Test 4 : Check Output Voltage of Main PCB • Check outdoor unit circuit diagram and the voltage. (Measure at Main PCB side connector)	<div style="border: 1px solid black; padding: 5px; display: inline-block;"> DC  </div>						
	<table border="1" style="width: 100%;"> <thead> <tr> <th>Read wire</th> <th>DC voltage</th> </tr> </thead> <tbody> <tr> <td>Red - Black</td> <td>260 - 400V</td> </tr> <tr> <td>White - Black</td> <td>15 ± 1.5V</td> </tr> </tbody> </table>	Read wire	DC voltage	Red - Black	260 - 400V	White - Black	15 ± 1.5V
Read wire	DC voltage						
Red - Black	260 - 400V						
White - Black	15 ± 1.5V						
▶ If the voltage is not correct, replace Main PCB.							

Trouble shooting 20 <u>OUTDOOR UNIT Error Method:</u> 4-Way Valve Error	<u>Indicate or Display:</u> Outdoor Unit : No indication Indoor Unit : Operation lamp: 9 times Flash, Timer lamp: 9 times Flash Economy lamp: Continuous flash. ERROR CODE : [E : 99]
--	--

<u>Detective Actuators:</u> Indoor Unit Controller PCB Circuit Heat Exchanger Temperature Thermistor Room Temperature Thermistor 4-way valve	<u>Detective details:</u> When the indoor heat exchanger temperature is compared with the room temperature, and either following condition is detected continuously two times, the compressor stops. •Cooling or Dry operation [Indoor heat exchanger temp.] - [Room temp.] > 40°F (20°C) •Heating operation [indoor heat exchanger temp.] - [Room temp.] < -40°F (-20°C) If the same operation is repeated 2 times, the compressor stops permanently.
---	---

<u>Forecast of Cause:</u> 1. Connector connection failure 2. Thermistor failure 3. Coil failure 4. 4-way valve failure 5. Main PCB failure

Test 1 : Check connection of Connector
<ul style="list-style-type: none"> • Check if connector is removed. • Check erroneous connection. • Check if thermistor cable is open. >> <u>Upon correcting the removed connector or miss-wiring, reset the power.</u>



Test 2 : Check thermistor of Indoor unit
<ul style="list-style-type: none"> • Isn't it fallen off the holder? • Is there a cable pinched? >> <u>Check characteristics of thermistor, (Refer to Trouble shooting 6,7), If defective, replace the thermistor.</u>



Test 3 : Check the solenoid coil and 4-way valve
<p>[Solenoid coil]</p> <ul style="list-style-type: none"> • Remove CN500 from PCB and check the resistance value of coil. Resistance value is about 1355Ω at 68°F(20°C) >> <u>If it is Open or abnormal resistance value, replace Solenoid Coil.</u> <p>[4-way valve]</p> <ul style="list-style-type: none"> • Check each piping temperature, and the location of the valve by the temperature difference. >> <u>If the value location is not proper, replace 4-way valve.</u>



Test 4 : Replace Main PCB
▶ <u>If Test 1- 3 do not improve the symptom, replace Main PCB.</u>

Trouble shooting 21 OUTDOOR UNIT Error Method: Discharge Temp. Error	Indicate or Display: Outdoor Unit : No indication Indoor Unit : Operation lamp: 10 times Flash, Timer lamp: 1 times Flash Economy lamp: Continuous flash. ERROR CODE : [E : A1]
---	---

Detective Actuators: Discharge Temperature Thermistor	Detective details: <ul style="list-style-type: none"> "Protection stop by "discharge temperature $\geq 239^{\circ}\text{F}$ (115°C) during compressor operation"" generated 2 times within 24 hours.
---	---

Forecast of Cause: 1. 3-way valve not opened 2. EEV defective, strainer clogged 3. Outdoor unit operation failure, foreign matter on heat exchanger 4. Discharge temperature thermistor failure 5. Insufficient refrigerant

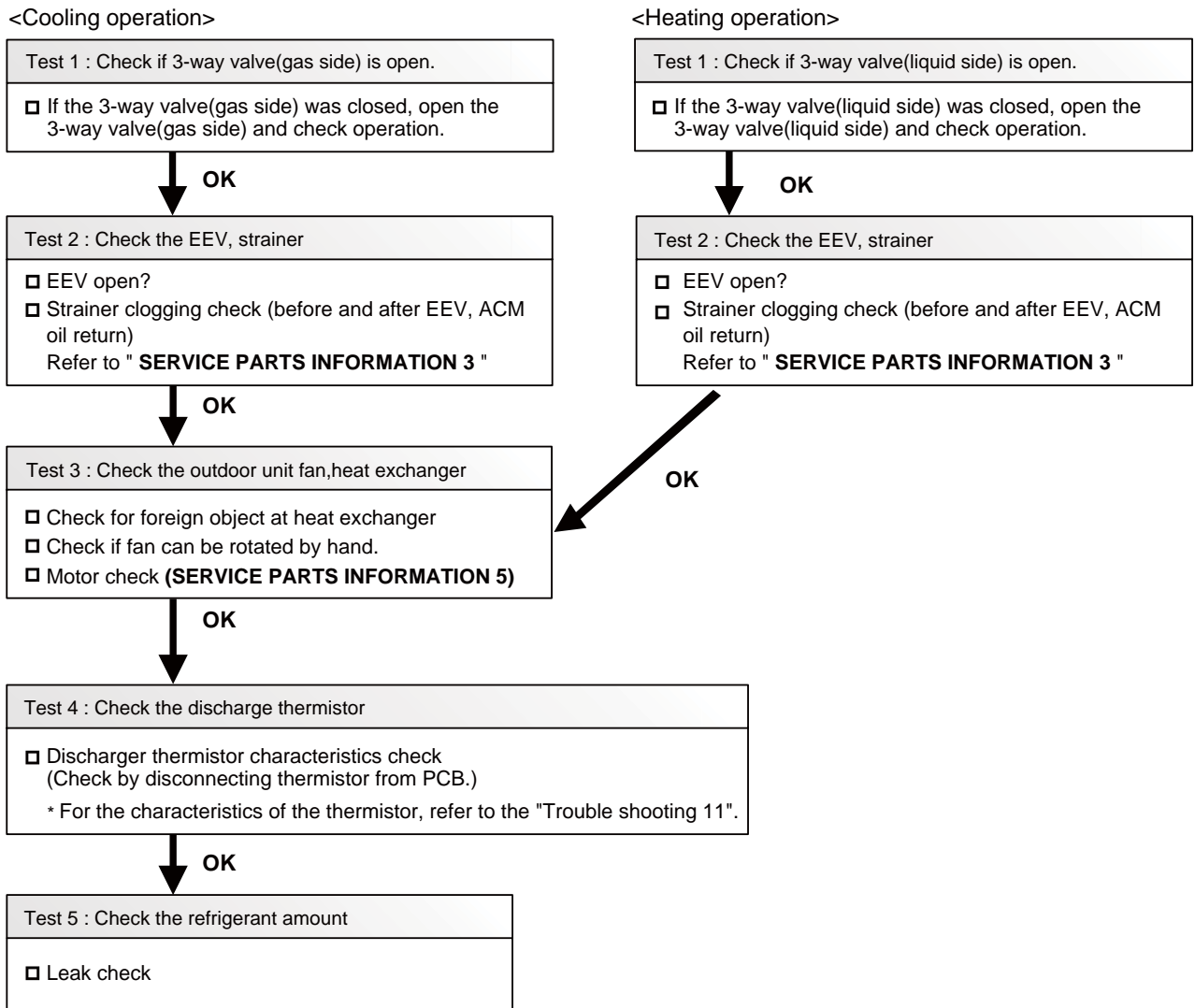

Trouble shooting 22 OUTDOOR UNIT Error Method: Compressor Temp. Error	Indicate or Display: Outdoor Unit : No indication Indoor Unit : Operation lamp: 10 times Flash, Timer lamp: 3 times Flash Economy lamp: Continuous flash. ERROR CODE : [E : A3]
--	---

Detective Actuators: Compressor Temperature Thermistor	Detective details: • "Protection stop by "compressor temperature $\geq 226.4^{\circ}\text{F}$ (108°C) during compressor operation"" generated 2 times within 24 hours.
--	--

Forecast of Cause: 1. 3-way valve not opened 2. EEV defective, strainer clogged 3. Outdoor unit operation failure, foreign matter on heat exchanger 4. Compressor temperature thermistor failure 5. Insufficient refrigerant 6. Main PCB failure

<Cooling operation>

Test 1 : Check if 3-way valve(gas side) is open.
<ul style="list-style-type: none"> • If the 3-way valve(gas side) was closed, open the 3-way valve(gas side) and check operation.

OK

Test 2 : Check the EEV, strainer
<ul style="list-style-type: none"> • EEV open? • Strainer clogging check Refer to " SERVICE PARTS INFORMATION 3 "

OK

Test 3 : Check the outdoor unit fan,heat exchanger
<ul style="list-style-type: none"> • Check for foreign object at heat exchanger • Check if fan can be rotated by hand. • Motor check (SERVICE PARTS INFORMATION 5)

OK

Test 4 : Check the thermistor Compressor
<ul style="list-style-type: none"> • Compressor thermistor characteristics check (Check by disconnecting thermistor from PCB.) * For the characteristics of the thermistor, refer to the "Trouble shooting 12".

OK

Test 5 : Check the refrigerant amount
<ul style="list-style-type: none"> • Leak check

<Heating operation>

Test 1 : Check if 3-way valve(liquid side) is open.
<ul style="list-style-type: none"> • If the 3-way valve(liquid side) was closed, open the 3-way valve(liquid side) and check operation.

OK

Test 2 : Check the EEV, strainer
<ul style="list-style-type: none"> • EEV open? • Strainer clogging check Refer to " SERVICE PARTS INFORMATION 3 "

OK

OK

OK

OK

OK

OK

OK

OK

OK

OK

OK

OK

OK

OK

OK

OK

OK

OK

OK

OK

OK

OK

OK

2-3 TROUBLE SHOOTING WITH NO ERROR CODE

Trouble shooting 23
Indoor Unit - No Power

Forecast of Cause:
1. Power Supply failure 2. External cause
3. Electrical Components defective

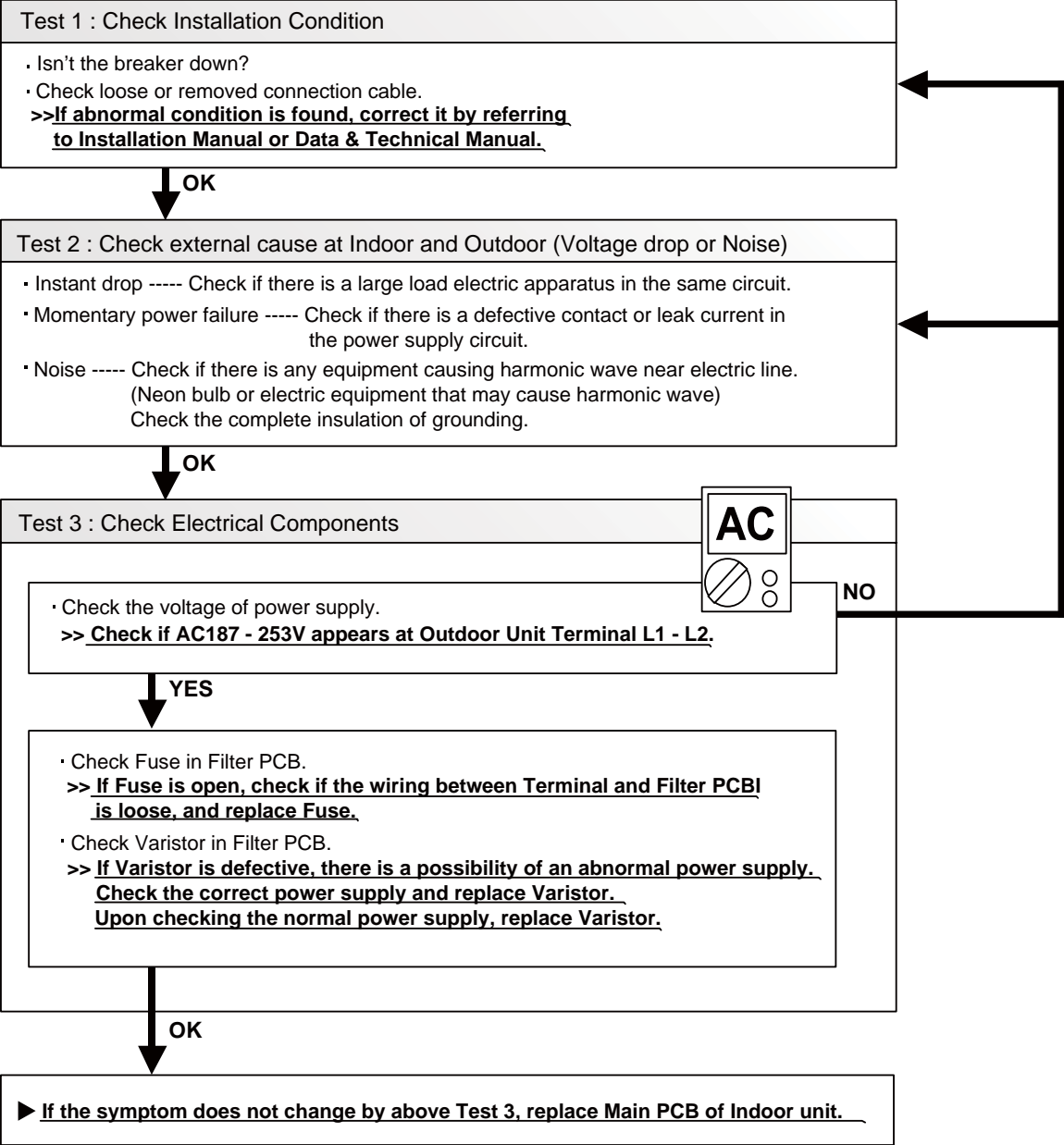

Trouble shooting 24

Outdoor Unit - No Power

Forecast of Cause:

1. Power Supply failure
2. External cause
3. Electrical Components defective

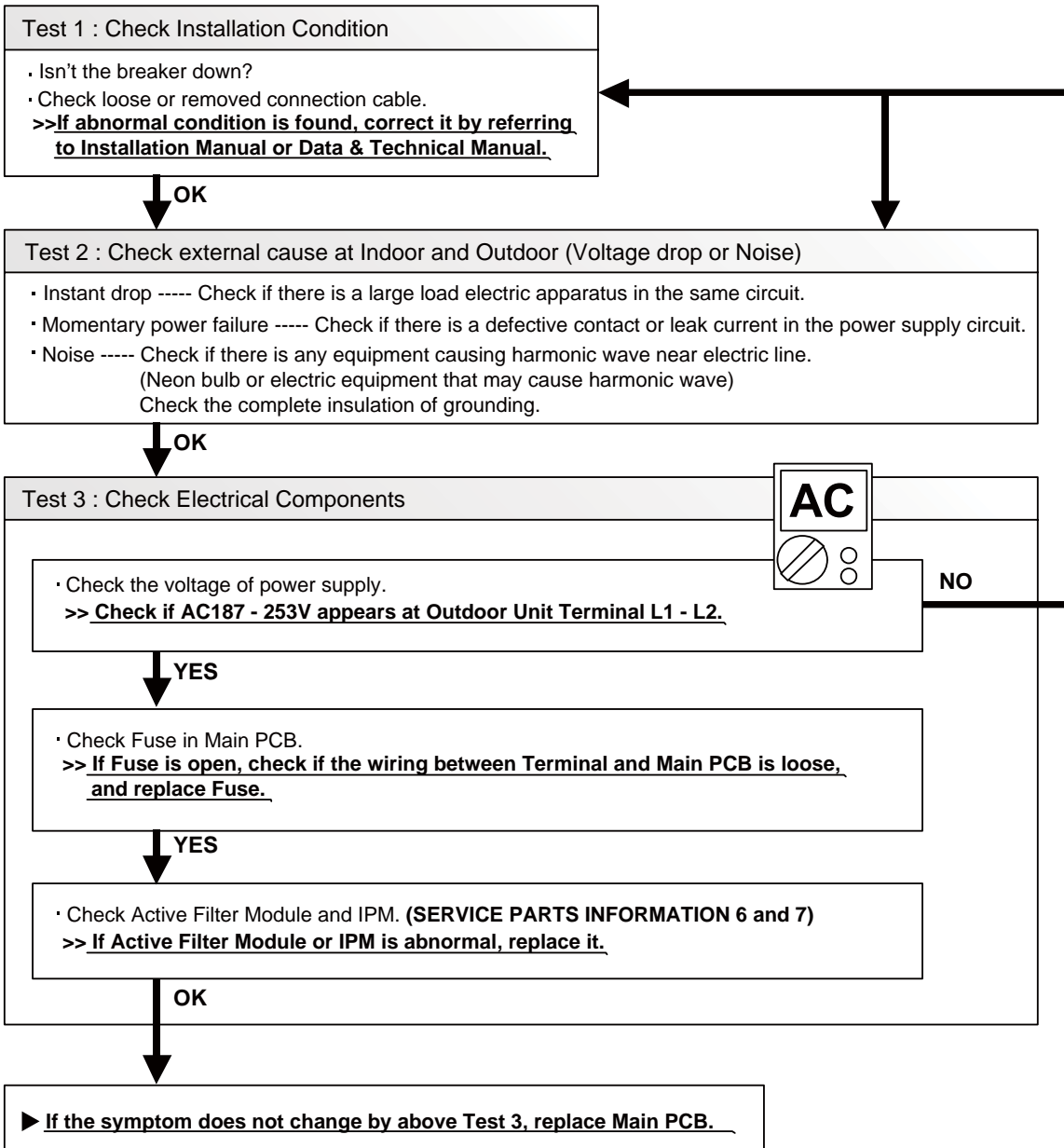

Trouble shooting 25

No Operation (Power is ON)

Forecast of Cause:

1. Setting/ Connection failure
2. External cause
3. Electrical Component defective

Test 1 : Check indoor and outdoor installation condition

- Indoor Unit - Check incorrect wiring between Indoor Unit - Remote Control.
Or, check if there is an open cable connection.
- Are these Indoor Unit, Outdoor Unit, and Remote Control suitable model numbers to connect?
>> If there is some abnormal condition, correct it by referring to Installation manual and Data & Technical Manual.

OK

Turn off Power and check/ correct followings.

- Is there loose or removed communication line of Indoor Unit and Outdoor Unit?

OK

Test 2 : Check external cause at Indoor and Outdoor (Voltage drop or Noise)

- Instant drop ----- Check if there is a large load electric apparatus in the same circuit.
- Momentary power failure ----- Check if there is a defective contact or leak current in the power supply circuit.
- Noise ----- Check if there is any equipment causing harmonic wave near electric line.
(Neon bulb or electric equipment that may cause harmonic wave)
Check the complete insulation of grounding.

OK

Test 3 : Check Wired Remote Controller and Controller PCB

- Check Voltage at CN6 (terminal 1-3) of Controller PCB.
(Power supply to Remote Control)

- >> If it is DC12V, Remote Control is failure. (Controller PCB is normal) >> Replace Remote Control**
- >> If it is DC 0V, Controller PCB is failure. (Check Remote Control once again) >> Replace Controller PCB**
- >> If the symptom does not change by above Test 1 ~ 3 replace Main PCB of Outdoor unit.**

DC



Trouble shooting 26

No Cooling / No Heating

Forecast of Cause:

1. Indoor Unit error
2. Outdoor Unit error
3. Effect by Surrounding environment
4. Connection Pipe / Connection Wire failure
5. Refrigeration cycle failure

Test 1 : Check Indoor Unit

- Does Indoor Unit FAN run on HIGH FAN?
- Is Air Filter dirty?
- Is Heat Exchanger clogged?
- Check if Energy save function is operated.

OK

Test 2 : Check Outdoor Unit Operation

- Check if Outdoor Unit is operating
- Check any objects that obstruct the air flow route.
- Check clogged Heat Exchanger.
- Is the Valve open?

OK

Test 3 : Check Site Condition

- Is capacity of Indoor Unit fitted to Room size?
- Any windows open? Or direct sunlight?

OK

Test 4 : Check Indoor/ Outdoor Installation Condition

- Check connection pipe (specified pipe length & Pipe diameter?)
- Check any loose or removed communication line.
- >> **If there is an abnormal condition, correct it by referring to Installation Manual or Data & Technical Manual.**

OK

Test 5 : Check Refrigeration Cycle

- Check if Strainer is clogged (Refer to the figure at right).
- Measure Gas Pressure and if there is a leakage, correct it.
- >> **When recharging the refrigerant, make sure to perform vacuuming, and recharge the specified amount.**
- Check EEV (**SERVICE PARTS INFORMATION 3**)
- Check Compressor (**SERVICE PARTS INFORMATION 1,2**)
- Check Heater Unit (**SERVICE PARTS INFORMATION 8**)

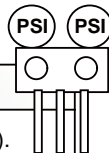

Attention

Strainer normally does not have temperature difference between inlet and outlet as shown in ①, but if there is a difference like shown in ②, there is a possibility of inside clogged. In this case, replace Strainer.

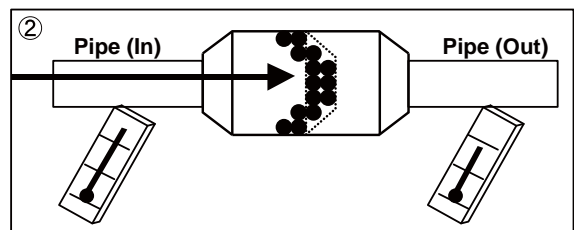
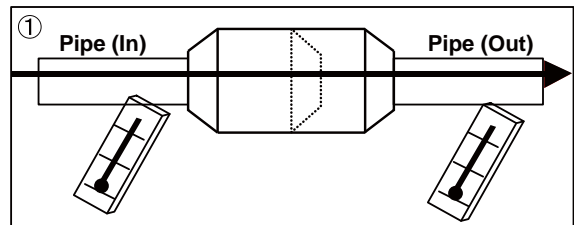

Trouble shooting 27

Abnormal Noise

Forecast of Cause :

1. Abnormal installation (Indoor/ Outdoor)
2. Fan failure (Indoor/ Outdoor)
3. Compressor failure (Outdoor)

Diagnosis method when Abnormal Noise is occurred

- Abnormal noise is coming from Indoor Unit.
(Check and correct followings)

- Is Main Unit installed in stable condition?
- Is the installation of Air suction grille and front panel normal?

OK

- Is Fan broken or deformed?
- Is the screw of Fan loose?
- Is there any object which obstruct the Fan rotation?

- Abnormal noise is coming from Outdoor Unit.
(Check and correct followings)

- Is Main Unit installed in stable condition?
- Is Fan Guard installed normally?

OK

- Is Fan broken or deformed?
- Is the screw of Fan loose?
- Is there any object which obstruct the Fan rotation?

OK

- Check if vibration noise by loose bolt or contact noise of piping is happening.

OK

- Is Compressor locked?
>> Check Compressor
(SERVICE PARTS INFORMATION 1,2)

Trouble shooting 28

Water Leaking

Forecast of Cause:

1. Erroneous installation
2. Drain hose failure

Diagnosis method when water leak occurs

- Is Main Unit installed in stable condition?
- Is Main Unit broken or deformed at the time of transportation or maintenance?

OK

- Is Drain Hose connection loose?
- Is there a trap in Drain Hose?
- Is Drain Hose clogged?

OK

- Is Fan rotating?

Diagnosis method when water is spitting out.

- Is the filter clogged?

OK

- Check Gas Pressure and correct it if there was a gas leak.

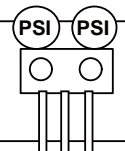

Trouble shooting 29

Too Warm

Forecast of Cause :

1. House insulation setting has not been changed.
2. Temperature sensing location has not been changed.
3. Installation location of the wired remote.
4. Function settings have not been changed.

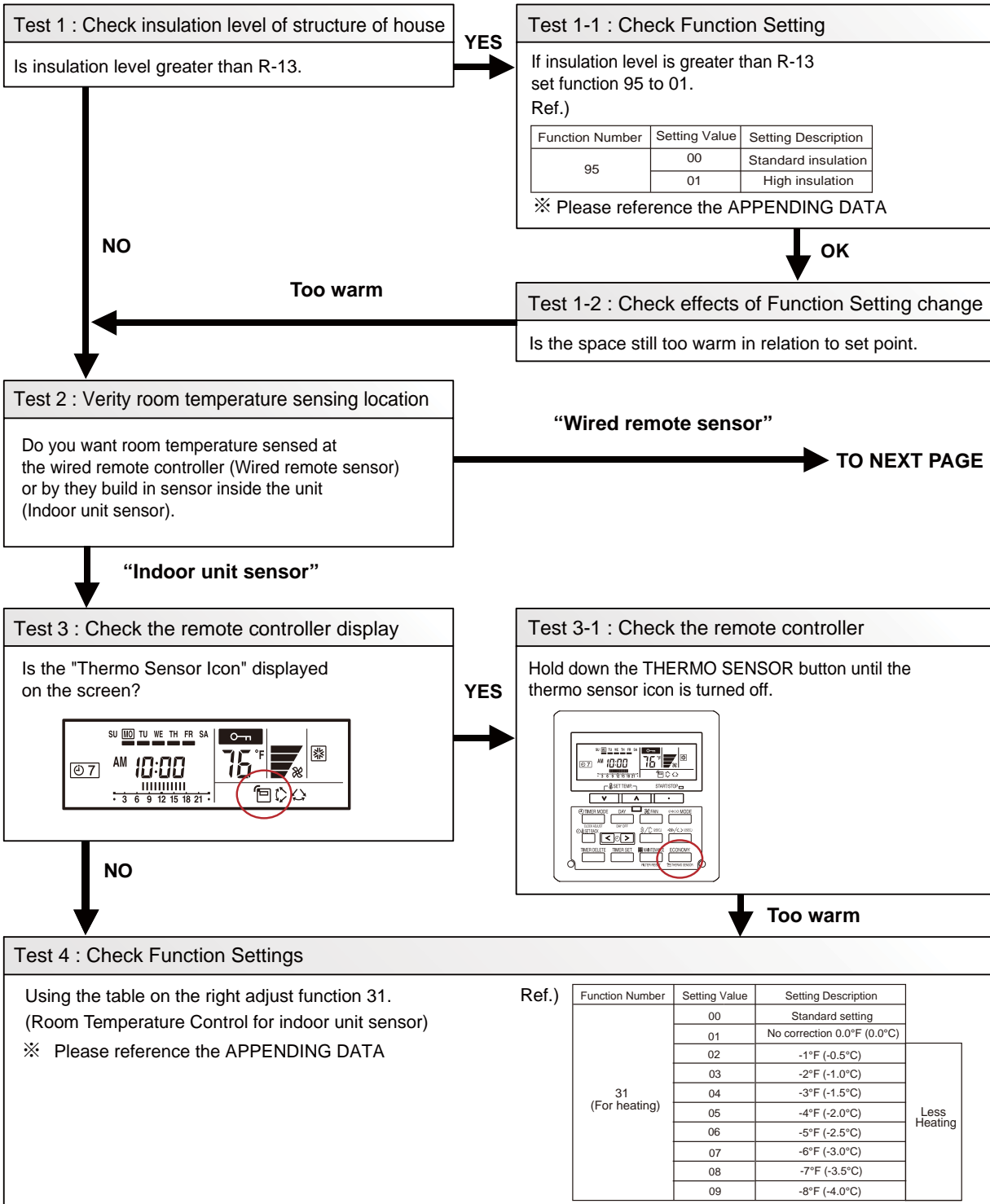

“Wired remote sensor”

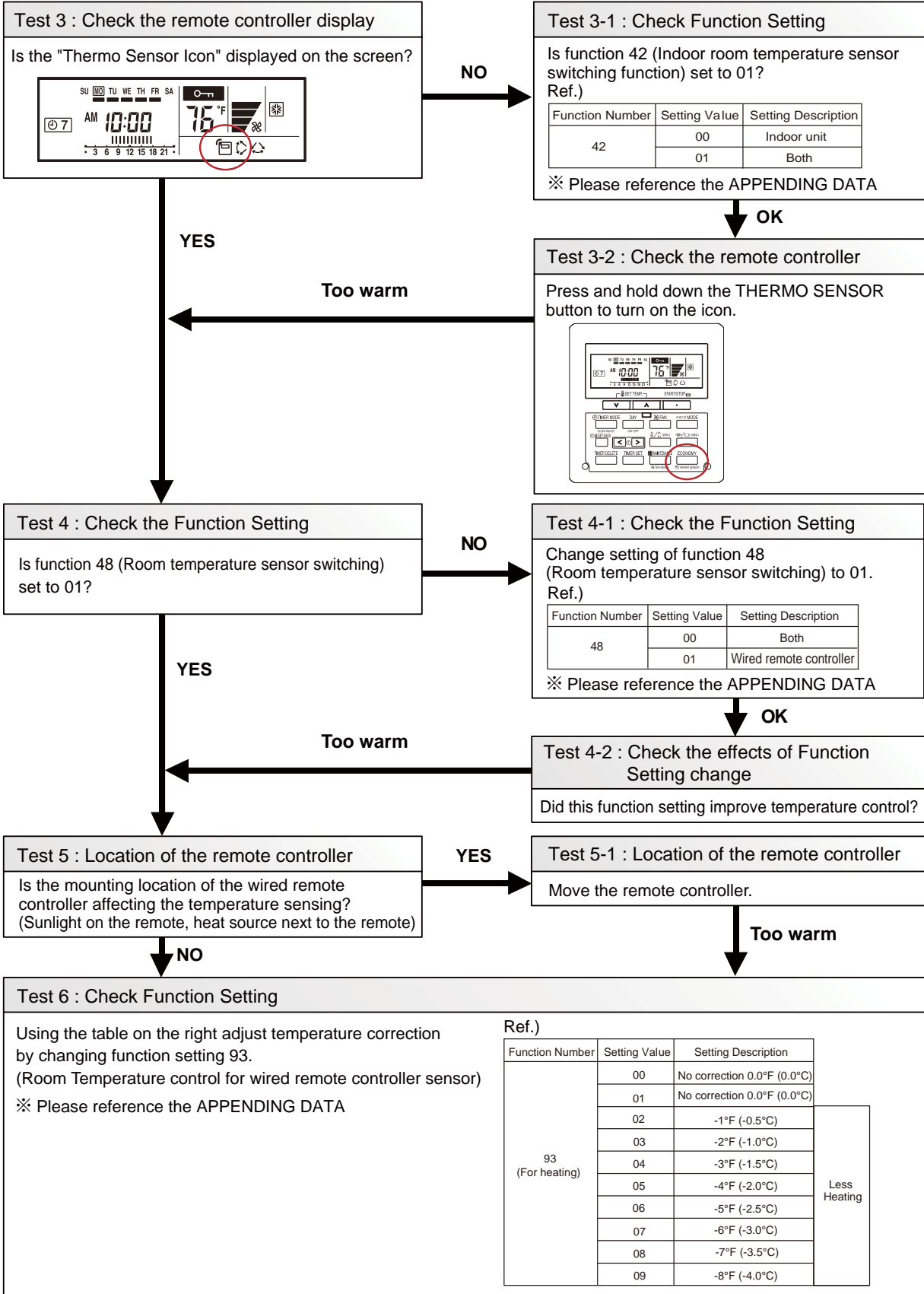

Trouble shooting 30

Too Cool

Forecast of Cause :

1. House insulation setting has not been changed.
2. Temperature sensing location has not been changed.
3. Installation location of the wired remote.
4. Function settings have not been changed.

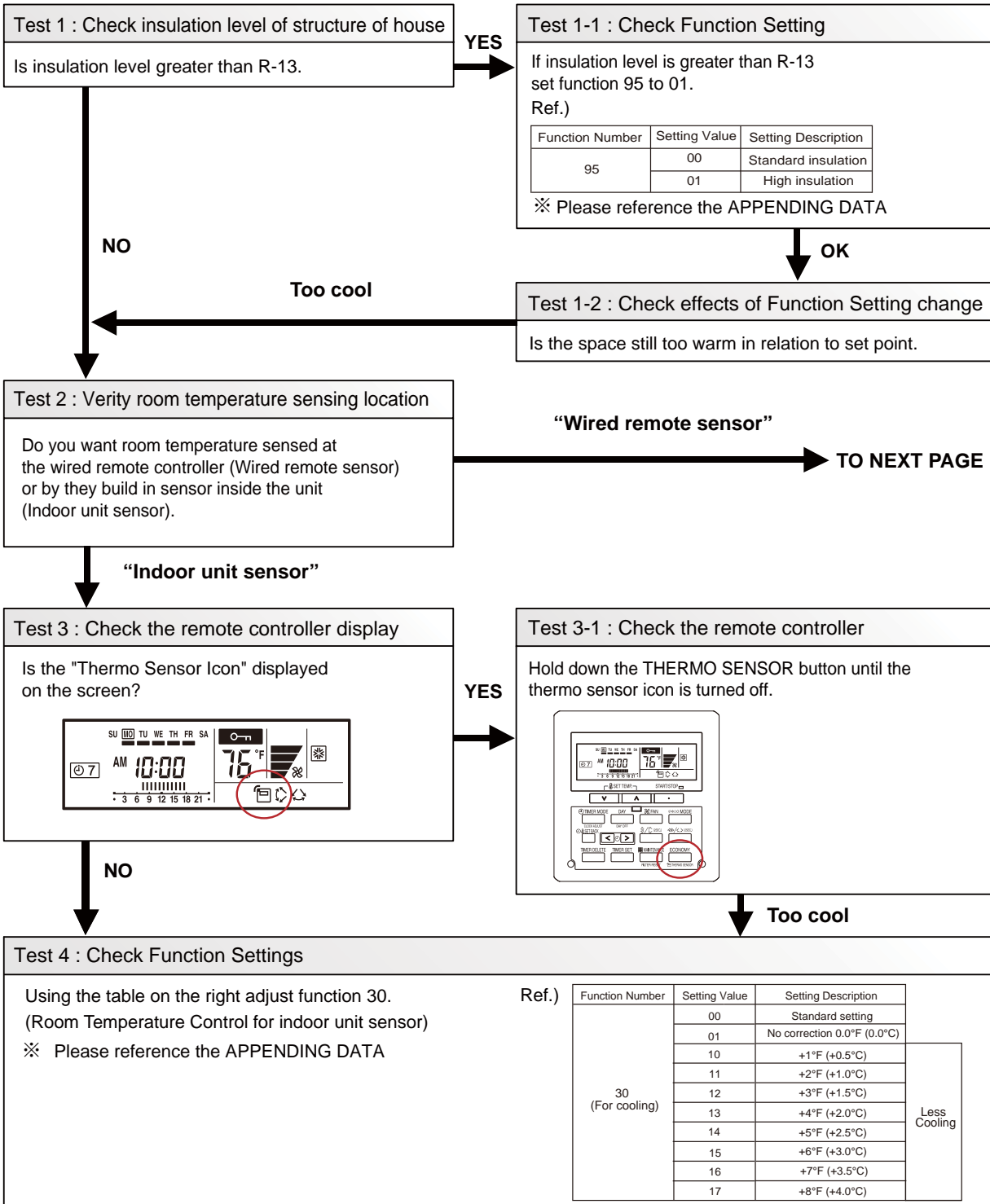

“Wired remote sensor”

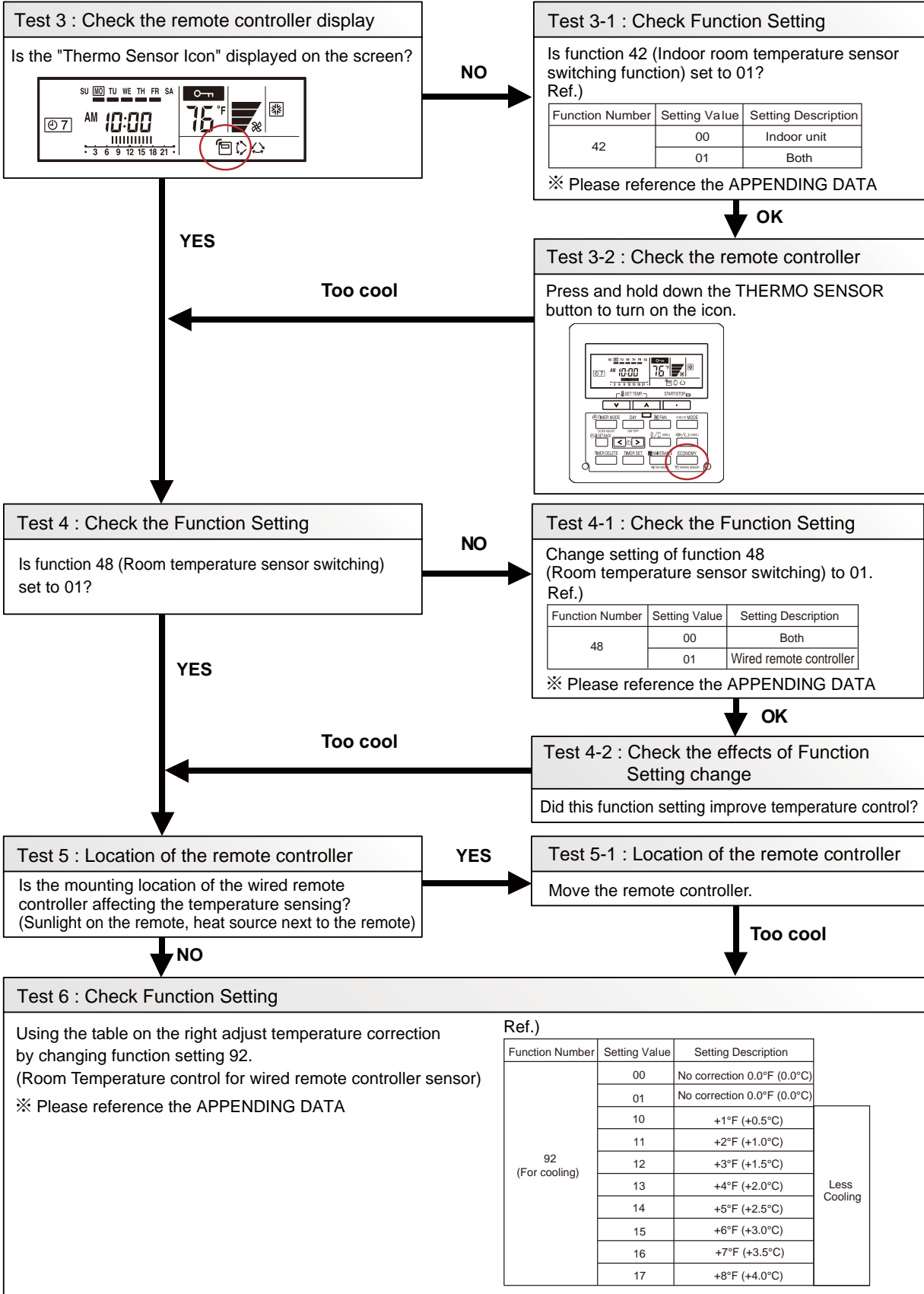

2-4 SERVICE PARTS INFORMATION

SERVICE PARTS INFORMATION 1
Compressor

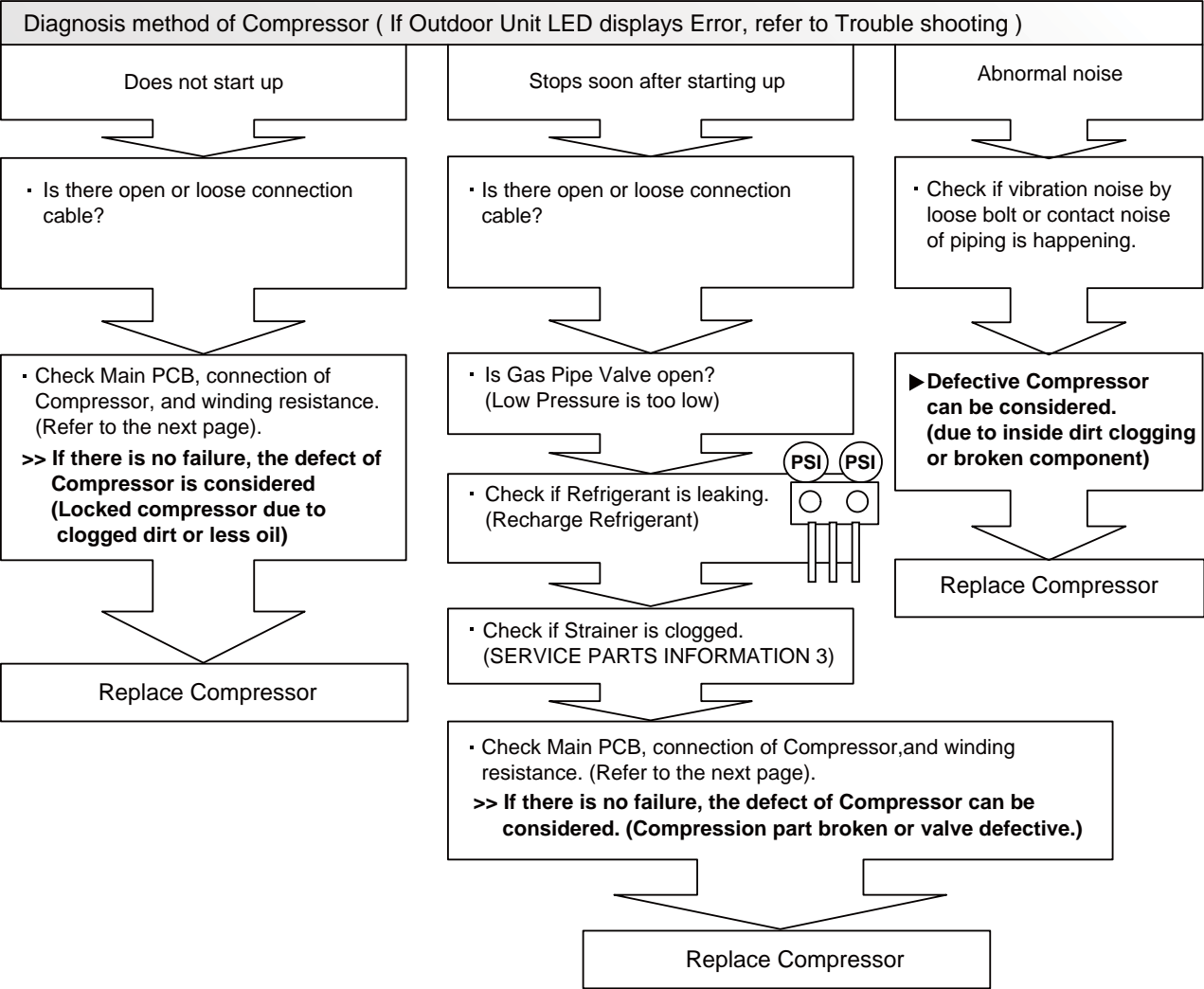

SERVICE PARTS INFORMATION 2

Inverter Compressor

Test 1 : Check Connection

- Check terminal connection of Compressor (loose or incorrect wiring)

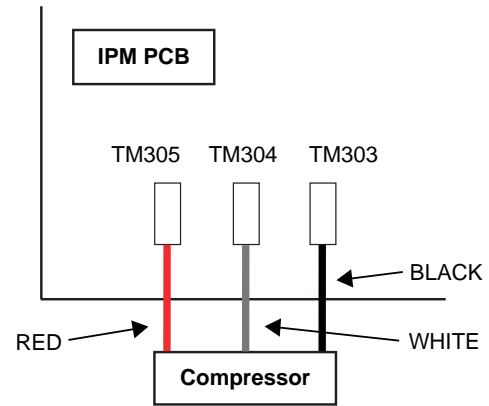
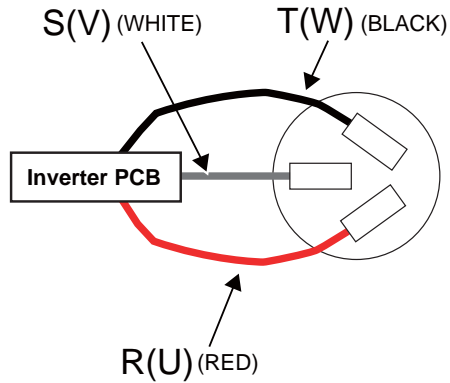

Test 2 : Check Winding Resistance

- Check winding resistance of each terminal

► **If the resistance value is 0Ω or infinite, replace Compressor.**

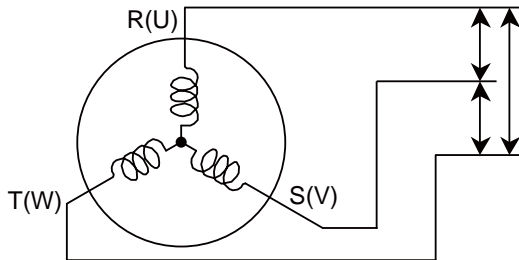

Resistance Value :
0.642Ω ± at 68°F(20°C)

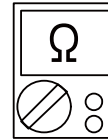

Test 3 : Replace Main PCB

► **If the symptom does not change with above Test 1, 2, replace Main PCB.**

SERVICE PARTS INFORMATION 3

Outdoor unit Electronic Expansion Valve (EEV)

Test 1 : Check Connections

- Check connection of connector (Loose connector or open cable)

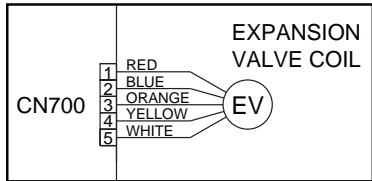

Test 2 : Check Coil of EEV

- Remove connector, check each winding resistance of Coil.

Read wire	Resistance value
White - Red	$46 \Omega \pm 4 \Omega$ at 68°F(20°C)
Yellow - Red	
Orange - Red	
Blue - Red	

► **If Resistance value is abnormal, replace EEV.**

Test 3 : Check Voltage from Main PCB.

- Remove Connector and check Voltage (DC12V)
- **If it does not appear, replace Main PCB.**



Test 4 : Check Noise at start up

- Turn on Power and check operation noise.
- **If an abnormal noise does not show, replace Main PCB.**

Test 5 : Check Opening and Closing Operation of Valve

When Valve is closed, it has a temp. difference between Inlet and Outlet.

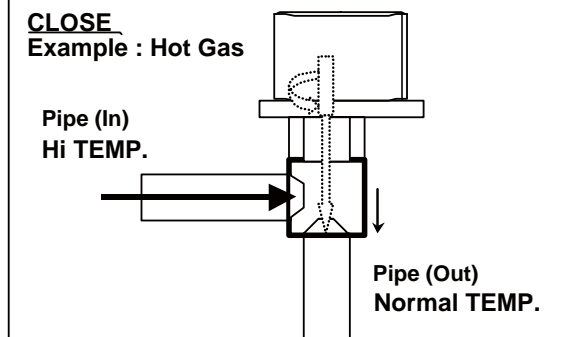

If it is open, it has no temp. difference between Inlet and Outlet.

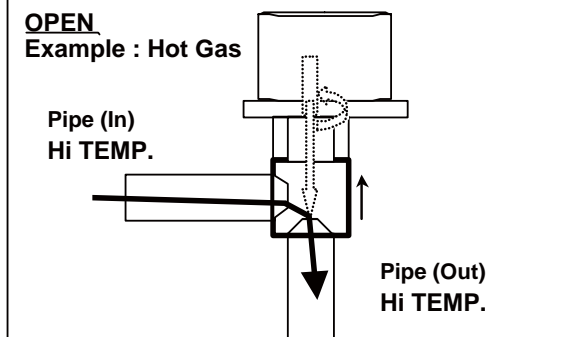

Test 6 : Check Strainer

Strainer normally does not have temperature difference between inlet and outlet as shown in ①, but if there is a difference as shown in ②, there is a possibility of inside clogged. In this case, replace Strainer.

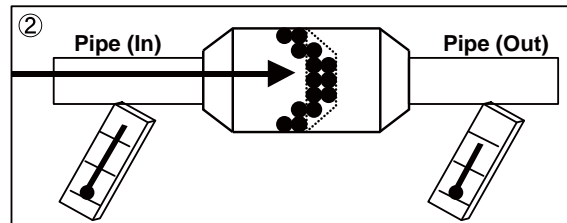
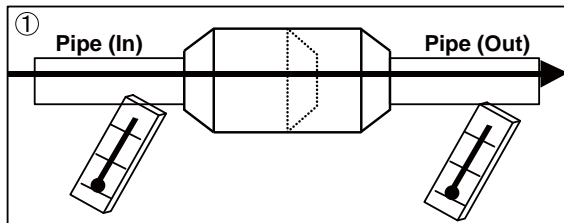

SERVICE PARTS INFORMATION 4

Indoor unit Fan motor

Test 1 : Check rotation of Fan

- Rotate the fan by hand when operation is off.
(Check if fan is caught, dropped off or locked motor)
- >>If Fan or Bearing is abnormal, replace it.**

Test 2 : Check resistance of Indoor Fan Motor

- Refer to below. Circuit-test "Vm" and "GND" terminal.
(Vm: DC voltage, GND: Earth terminal)
- >>If they are short-circuited (below 300 k Ω), replace Indoor fan motor and Controller PCB.**

Pin number (wire color)	Terminal function (symbol)
1 (Blue)	Feed back (FG)
2 (Yellow)	Speed command (Vsp)
3 (White)	Control voltage (Vcc)
4 (Black)	Earth terminal (GND)
5	No function
6 (Red)	DC voltage (Vm)

SERVICE PARTS INFORMATION 5

Outdoor unit Fan motor

Test 1 : Check rotation of Fan

- Rotate the fan by hand when operation is off.
(Check if fan is caught, dropped off or locked motor)
- >>If Fan or Bearing is abnormal, replace it.**

Test 2 : Check resistance of Outdoor Fan Motor

- Refer to below. Circuit-test "Vm" and "GND" terminal.
(Vm: DC voltage, GND: Earth terminal)
- >>If they are short-circuited (below 300 k Ω), replace Outdoor fan motor and Main PCB.**

Pin number (wire color)	Terminal function (symbol)
1 (Red)	DC voltage (Vm)
2	No function
3	No function
4 (Black)	Earth terminal (GND)
5 (White)	Control voltage (Vcc)
6 (Yellow)	Speed command (Vsp)
7 (Brown)	Feed back (FG)

SERVICE PARTS INFORMATION 6

Active filter module

Test 1 : Check Open or Short-circuit and Diode (D1)

· Remove connector, check the open or short-circuit and the diode in the module

Check the open or short-circuit

Table.1 Each type standard value

Terminal		Resistance value	
		Type A	Type B
multimeter (+)	multimeter (-)	SACT32010 [HITACHI] LACT33020 [HITACHI]	PM-604 [FGEL] PM-703 [FGEL]
		PM-601 [FGEL] <u>LOT No. - 1302931395</u>	PM-601 [FGEL] <u>LOT No. 1302931396 -</u>
+ (+IN)*	- (-IN)*	360kΩ ± 20%	360kΩ ± 20%
- (-IN)*	N1 (N)*	0 Ω	0 Ω
※ P	+ (+IN)*	720kΩ ± 20%	900kΩ ± 20%
L1	L2	1.01MΩ / 0.76MΩ (Ref. value 1) (Ref. value 2)	1.01MΩ / 0.76MΩ (Ref. value 1) (Ref. value 2)
P	N1 (N)*	360kΩ ± 20%	540kΩ ± 20%
L1, L2	Control Box	∞ Ω	∞ Ω
※ L2	N1 (N)*	1.65MΩ / 1.14MΩ (Ref. value 1) (Ref. value 2)	1.65MΩ / 1.14MΩ (Ref. value 1) (Ref. value 2)

* () is FGEL terminal name.

Table.2 Standard value is changed by the tool specification
(Type A and B are the same value)

Terminal		Resistance value
multimeter (+)	multimeter (-)	
※ L2	P	1.32MΩ / 0.66MΩ (Ref. value 1) (Ref. value 2)
※ P	L2	1.01MΩ / 0.76MΩ (Ref. value 1) (Ref. value 2)

※ By kind of multimeter , the value may change significantly.

Ref. value 1

Specifications for Multimeter
Manufacturer : FLUKE
Model name : FLUKE11
Power source : DC9V.

Ref. value 2

Specifications for Multimeter
Manufacturer : SANWA
Model name : PM3
Power source : DC3V.

▶ If it is abnormal,replace ACTIVE FILTER MODULE

LOT No. of PM-601 [FGEL] type

Label position

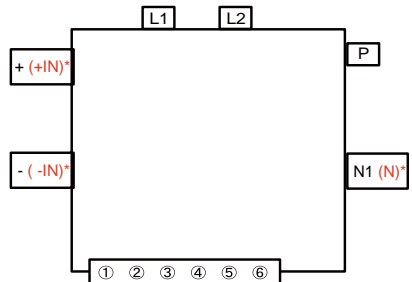
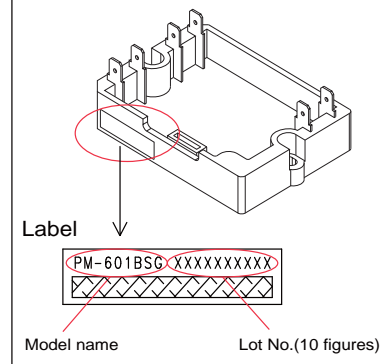

Test 2 : Check the Output DC voltage (between P and N)

· Check the Output DC voltage (between P and N) of compressor stopping and operating.

>> If the output voltage of compressor operating is less than the output voltage of compressor stopping,
Active Filter Module is defective. >> Replace Active Filter Module

SERVICE PARTS INFORMATION 7

IPM

(Mounted on Transistor PCB)

Test 1 : Check the Transistor PCB (for Resistance)

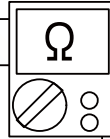

- ① Disconnect the connection wires between the Transistor PCB - Capacitor PCB and Transistor PCB - Inverter Compressor.
- ② Set the tester to the "Resistance" mode, and measure the resistance between the following terminals.
 TM301 (P) - TM305(U) / TM304(V) / TM303(W)
 TM302 (N) - TM305(U) / TM304(V) / TM303(W)
- ③ Judge the result of ② as follows:

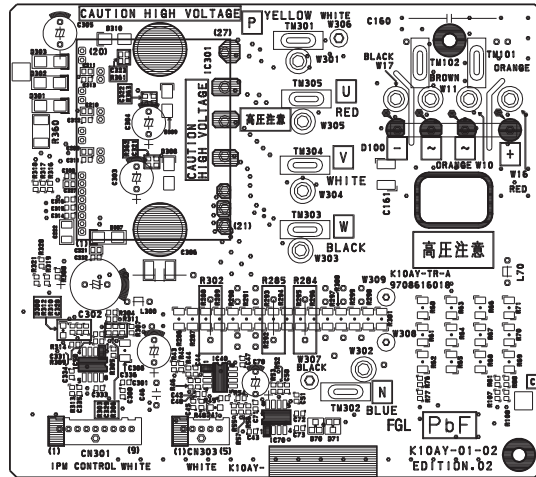

Terminal		Resistance value
Tester(+)	Tester(-)	
P	U	Over 2kΩ (Including ∞Ω)
P	V	
P	W	
U	P	Over 20kΩ (Including ∞Ω)
V	P	
W	P	
N	U	
N	V	Over 2kΩ (Including ∞Ω)
N	W	
U	N	
V	N	Over 2kΩ (Including ∞Ω)
W	N	

Test 2 : Check the Transistor PCB (for Diode)

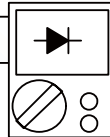

- ④ Set the tester to the "Diode" mode, and measure the voltage value between the following terminals.
- ⑤ Judge the result of ④ as follows:

Terminal		Tester display
Tester(+)	Tester(-)	
P	U	∞
P	V	
P	W	
U	P	0.3V ~ 0.7V
V	P	
W	P	
N	U	
N	V	∞
N	W	
U	N	
V	N	∞
W	N	

SERVICE PARTS INFORMATION 8

Heater Unit

Check Point 1 : Check Connections

- Check connection of connector
(Loose connector or open cable)

AOU18/24RLXFWH



Check Point 2 : Check electrical components

- Check Check Fuses.
>> If Fuse is open, check connection, and replace Fuse.

Check Point 3 : Check Heater wire.

- Remove connector, check resistance of Heater wire.

Read wire	Resistance value
Black - White	321 ~ 368 Ω at 77°F(25°C)

- ▶ **If Resistance value is abnormal, replace Heater Unit.**

WALL MOUNTED type INVERTER

3 . APPENDING DATA

3-1. FUNCTION SETTING

3-1-1 INDOOR UNIT

- Follow the instructions in the Local Setup Procedure, which is supplied with the remote control, in accordance with the installed condition.
After the power is turned on, perform the Function Setting on the remote control.
- The settings may be selected between the following two: Function Number or Setting Value.
- Settings will not be changed if invalid numbers or setting values are selected.

Function Details

1-1. Setting the Filter sign

Select appropriate intervals for displaying the filter sign on the indoor unit according to the estimated amount of dust in the air of the room.
If the indication is not required, select "No indication" (03).

(◆ . . . Factory setting)

Function Number	Setting Value	Setting Description
11	00	Standard (400 hours)
	01	Long interval (1000 hours)
	02	Short interval (200 hours)
	03	No indication

1-2. Setting the Auto restart

Enable or disable automatic restart after a power interruption.

(◆ . . . Factory setting)

Function Number	Setting Value	Setting Description
40	00	Enable
	01	Disable

Auto restart is an emergency function such as for power outage etc.
Do not attempt to use this function in normal operation.
Be sure to operate the unit by remote controller or external device.

1-3. Setting the Room temperature sensor switching

(Only for Wired remote controller)

When using the Wired remote controller temperature sensor , change the setting to "Both" (01).

(◆ . . . Factory setting)

Function Number	Setting Value	Setting Description
42	00	Indoor unit
	01	Both

00: Sensor on the indoor unit is active.

01: Sensors on both indoor unit and wired remote controller are active.

- Remote controller sensor must be turned on by using the remote controller.

**1-4. Setting the Remote controller custom code
(Only for wireless remote controller)**

The indoor unit custom code can be changed.
Select the appropriate custom code.

(◆ . . .Factory setting)

Function Number	Setting Value	Setting Description
44	00	A
	01	B
	02	C
	03	D

1-5. Setting the External input control

"Operation / Stop" mode or "Forced stop" mode can be selected.

(◆ . . .Factory setting)

Function Number	Setting Value	Setting Description
46	00	Operation / Stop mode
	01	(Setting prohibited)
	02	Forced stop mode

1-6. Setting the Room temperature sensor switching (Aux.)

To use the temperature sensor on the wired remote controller only,
change the setting to "Wired remote controller" (01).
This function will only work if the function setting 42 is set at "Both" (01)

(◆ . . .Factory setting)

Function Number	Setting Value	Setting Description
48	00	Both
	01	Wired remote controller

Temperature Correction

When changing Function 95, perform this setting before other Room temp. control settings (Function 30, 31, 92, 93).

If Function 95 is not set first, Room temperature control settings (Function 30, 31, 92, 93) will be reset and you must re-do them again.

1-7. Setting the Heat Insulation condition (building insulation)

Heat insulation conditions differ according to the installed environment.

Standard insulation "00" allows system to rapidly respond to the cooling or heating load changes.

High insulation "01" is when the heat insulation structure of the building is high and does not require system to rapidly respond to cooling or heating load changes. When High insulation "01" is selected;

- Overheating (overcooling) is prevented at the start-up.
- All room temp. control settings (Function 30, 31, 92, 93) will reset to No correction [0.0°F (0.0°C)].

(◆ . . . Factory setting)

Function Number	Setting Value	Setting Description
95	00	Standard insulation ◆
	01	High insulation

1-8. Setting the Room temperature control for indoor unit sensor

Depending on the installed environment, correction of the room temperature sensor may be required.

Select the appropriate control setting according to the installed environment.

The temperature correction values show the difference from the Standard setting "00" (manufacturer's recommended value).

- When Function 95-01 (High insulation) is set, the Standard setting "00" will be the same as No correction "01" [0.0°F (0.0°C)].

(◆ . . . Factory setting)

Function Number	Setting Value	Setting Description		
30 (For cooling)	31 (For heating)	00	Standard setting ◆	
		01	No correction 0.0°F (0.0°C)	
		02	-1°F (-0.5°C)	More Cooling Less Heating
		03	-2°F (-1.0°C)	
		04	-3°F (-1.5°C)	
		05	-4°F (-2.0°C)	
		06	-5°F (-2.5°C)	
		07	-6°F (-3.0°C)	
		08	-7°F (-3.5°C)	
		09	-8°F (-4.0°C)	Less Cooling More Heating
		10	+1°F (+0.5°C)	
		11	+2°F (+1.0°C)	
		12	+3°F (+1.5°C)	
		13	+4°F (+2.0°C)	
		14	+5°F (+2.5°C)	
		15	+6°F (+3.0°C)	
		16	+7°F (+3.5°C)	
17	+8°F (+4.0°C)			

1-9. Setting the Room temperature control for wired remote controller sensor

Depending on the installed environment, correction of the wire remote temperature sensor may be required. Select the appropriate control setting according to the installed environment. To change this setting, set Function 42 to Both "01". Ensure that the Thermo Sensor icon is displayed on the remote controller screen.

(◆ . . . Factory setting)

Function Number		Setting Value	Setting Description	
92 (For cooling)	93 (For heating)	00	No correction 0.0°F (0.0°C)	◆
		01	No correction 0.0°F (0.0°C)	
		02	-1°F (-0.5°C)	More Cooling Less Heating
		03	-2°F (-1.0°C)	
		04	-3°F (-1.5°C)	
		05	-4°F (-2.0°C)	
		06	-5°F (-2.5°C)	
		07	-6°F (-3.0°C)	
		08	-7°F (-3.5°C)	
		09	-8°F (-4.0°C)	
		10	+1°F (+0.5°C)	Less Cooling More Heating
		11	+2°F (+1.0°C)	
		12	+3°F (+1.5°C)	
		13	+4°F (+2.0°C)	
		14	+5°F (+2.5°C)	
		15	+6°F (+3.0°C)	
		16	+7°F (+3.5°C)	
		17	+8°F (+4.0°C)	

3-1-2 PROCEDURE TO CHANGE THE FUNCTION SETTING FOR WIRELESS RC

- This procedure changes to the function settings used to control the indoor unit according to the installation conditions. Incorrect settings can cause the indoor unit malfunction.
- After the power is turned on, perform the "FUNCTION SETTING" according to the installation conditions using the remote controller.
- Settings will not be changed if invalid numbers or setting values are selected.

Entering the Function Setting Mode

- While pressing the FAN button and SET TEMP.(▲) simultaneously, press the RESET button to enter the function setting mode.

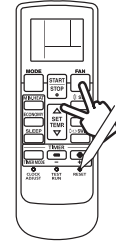

Selecting the Function Number and Setting Value

- (1) Press the MODE button, and proceed to Function Number and Setting Value.
(There is no necessity for setting remote control signal code.
Because signal code is setting by Function Number and Setting Value.)

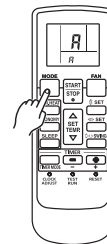

- (2) Press the SET TEMP. (▲) (▼) buttons to select the Function Number.
(Press the MODE button to switch between the left and right digits.)
- (3) Press the FAN button to proceed to Setting Value.
(Press the FAN button again to return to the Function Number selection.)
- (4) Press the SET TEMP. (▲) (▼) buttons to select the Setting Value.
(Press the MODE button to switch between the left and right digits.)

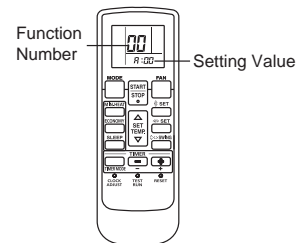

- (5) Press the TIMER MODE button. It makes a signal to indoor unit.
(Indoor unit recognize the setting.)
- (6) Press the START/STOP button. It makes a signal to indoor unit.
(Indoor unit run the setting.)

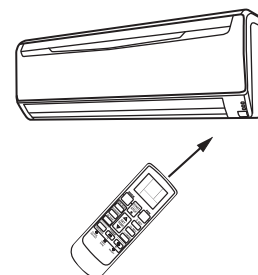

- (7) Press the RESET button to cancel the function setting mode.
- (8) After completing the FUNCTION SETTING, be sure to turn of the power and turn it on again.

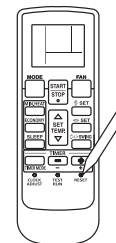

CAUTION

After turning off the power, wait 10 seconds or more before turning on it again.
The FUNCTION SETTING doesn't become effective if it doesn't do so.

Custom code setting for remote controller

- (1) Press the MODE button for more than 5 seconds.
- (2) Press the SET TEMP. (▲) (▼) buttons to change the signal code between $\overline{A} \rightarrow \overline{B} \rightarrow \overline{C} \rightarrow \overline{D}$.
Match the code on the display to the air conditioner signal code. (initially set to \overline{A})
- (3) Press the MODE button. (Return to normal display)

CAUTION

If you change the setting of Function Number and Setting Value after setting custom code in remote controller, please set custom code in remote controller again.

The remote control unit resets to signal code A when the batteries in the remote control unit are replaced.

If you use a signal code other than signal code A, reset the signal code after replacing the batteries.

If you do not know the air conditioner signal code setting, try each of the signal codes ($\overline{A} \rightarrow \overline{B} \rightarrow \overline{C} \rightarrow \overline{D}$) until you find the code which operates the air conditioner.

3-2. OUTDOOR UNIT PRESSURE VALUE AND TOTAL ELECTRIC CURRENT CURVE

Outdoor Unit Low Pressure Value and Outdoor Total Electric Current Curve (Cooling)

Model Name : ASU18RLF

[Condition]

Ambient temperature : Indoor / Outdoor - Same temperature

Refrigerant amount : Standard amount

Piping length : 25ft. (Height difference 39inch.) 7.5m (Height difference 1m)

Power voltage : 60Hz - 230V

Operation condition : TEST mode (Cooling), Hi Fan, Horizontal direction, Front air flow

Measuring : method : Measure the low pressure with the pressure meter at the service valve.
Measure the outdoor unit overall current with the current clamp meter at Power Cable.

Caution : Start operation with the condition of the Indoor Unit air filter clean.

[Constant Frequency Operation Method (Test mode)]

1. Operate on Cooling mode, and press TEST button of remote control.
2. Operate continuously for 30 minutes. (After 60 minutes of operation, Test mode is released automatically.)

(1) Indoor/Outdoor Temperature - Outdoor Low Pressure Curve

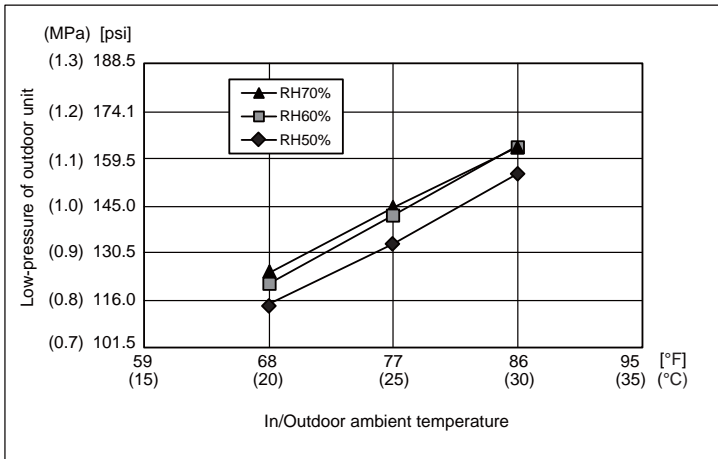

(2) Indoor/Outdoor Temperature - Outdoor Total Electric Current Curve

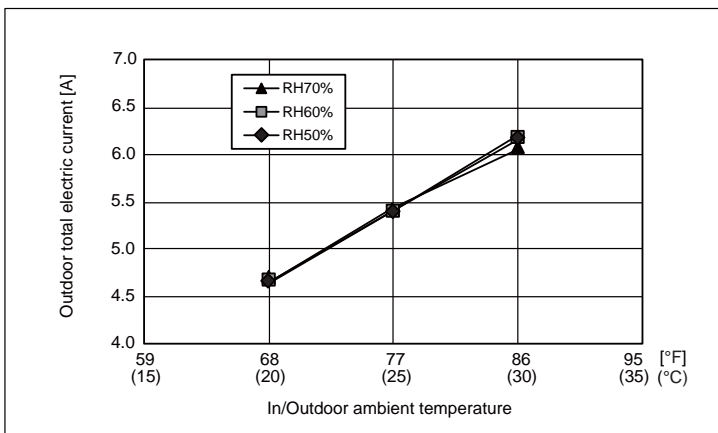

Outdoor Unit High Pressure Value and Outdoor Total Electric Current Curve (Heating)

Model Name : ASU18RLF

[Condition]

Ambient temperature : Indoor 59°F, 68°F, 73.4°F, Outdoor 35.6°F, 44.6°F, 53.6°F
(15°C, 20°C, 23°C) (2°C, 7°C, 12°C)

Refrigerant amount : Standard amount

Piping length : 7.5m (Height difference 1m)

Power voltage : 60Hz - 230V

Operation condition : TEST mode (Heating), Hi Fan, Lower direction, Front air flow

Measuring method : outdoor unit overall current with the current clamp meter at Power Cable.

Caution : Start operation with the condition of the Indoor Unit air filter clean.

[Constant Frequency Operation Method (Test mode)]

1. Operate on Heating mode, and press TEST button of remote control.
2. Operate continuously for 30 minutes. (After 60 minutes of operation, Test mode is released automatically.)

(1) Indoor/Outdoor Temperature - Outdoor High Pressure Curve

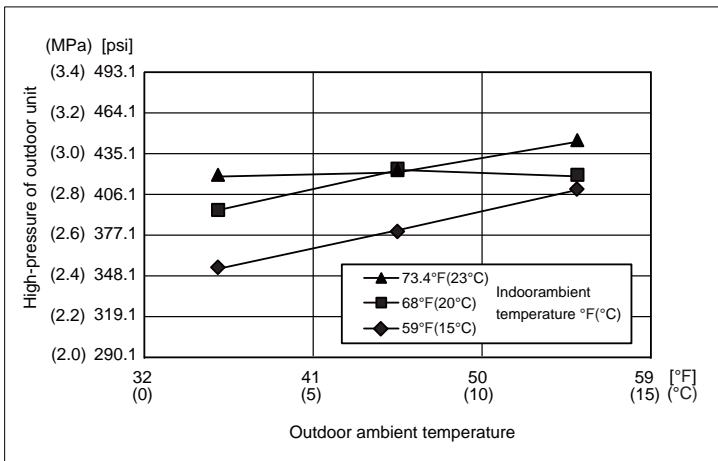

(2) Indoor/Outdoor Temperature - Outdoor Total Electric Current Curve

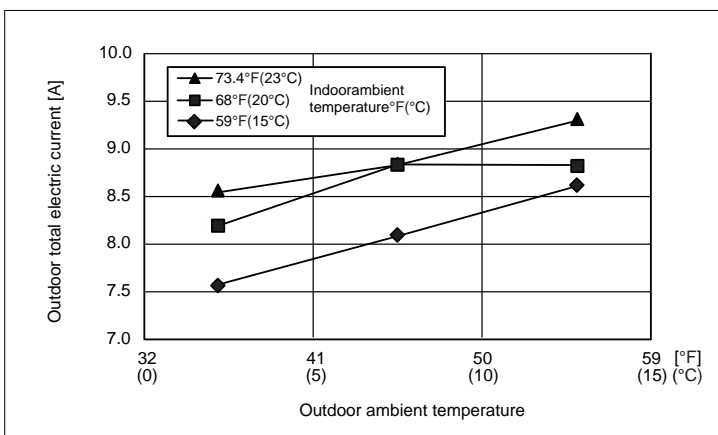

Outdoor Unit Low Pressure Value and Outdoor Total Electric Current Curve (Cooling)

Model Name : ASU24RLF

[Condition]

Ambient temperature : Indoor / Outdoor - Same temperature

Refrigerant amount : Standard amount

Piping length : 7.5m (Height difference 1m)

Power voltage : 60Hz - 230V

Operation condition : TEST mode (Cooling), Hi Fan, Horizontal direction, Front air flow

Measuring method : Measure the low pressure with the pressure meter at the service valve.
Measure the outdoor unit overall current with the current clamp meter at Power Cable.

Caution : Start operation with the condition of the Indoor Unit air filter clean.

[Constant Frequency Operation Method (Test mode)]

1. Operate on Cooling mode, and press TEST button of remote control.
2. Operate continuously for 30 minutes. (After 60 minutes of operation, Test mode is released automatically.)

(1) Indoor/Outdoor Temperature - Outdoor Low Pressure Curve

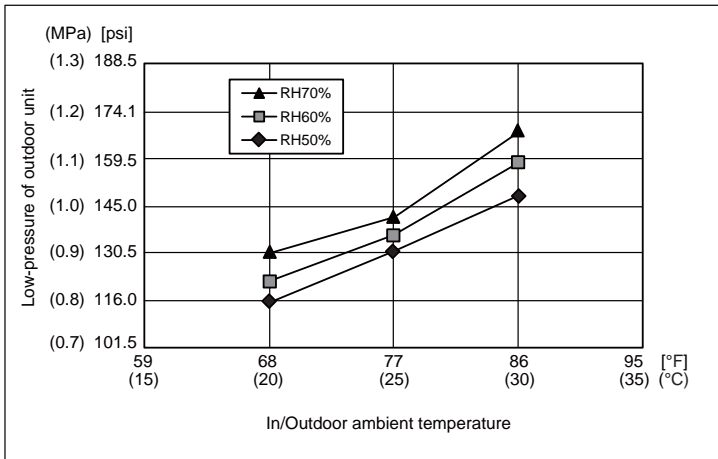

(2) Indoor/Outdoor Temperature - Outdoor Total Electric Current Curve

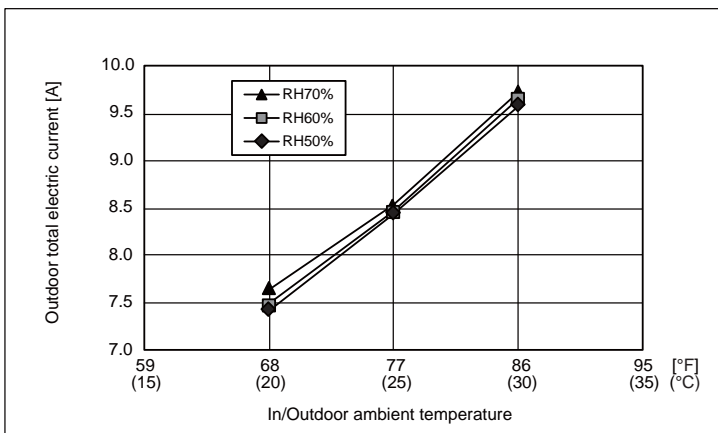

Outdoor Unit High Pressure Value and Outdoor Total Electric Current Curve (Heating)

Model Name : ASU24RLF

[Condition]

Ambient temperature : Indoor 59°F, 68°F, 73.4°F, Outdoor 35.6°F, 44.6°F, 53.6°F
(15°C, 20°C, 23°C) (2°C, 7°C, 12°C)

Refrigerant amount : Standard amount

Piping length : 7.5m (Height difference 1m)

Power voltage : 60Hz - 230V

Operation condition : TEST mode (Heating), Hi Fan, Lower direction, Front air flow

Measuring method : outdoor unit overall current with the current clamp meter at Power Cable.

Caution : Start operation with the condition of the Indoor Unit air filter clean.

[Constant Frequency Operation Method (Test mode)]

1. Operate on Heating mode, and press TEST button of remote control.
2. Operate continuously for 30 minutes. (After 60 minutes of operation, Test mode is released automatically.)

(1) Indoor/Outdoor Temperature - Outdoor High Pressure Curve

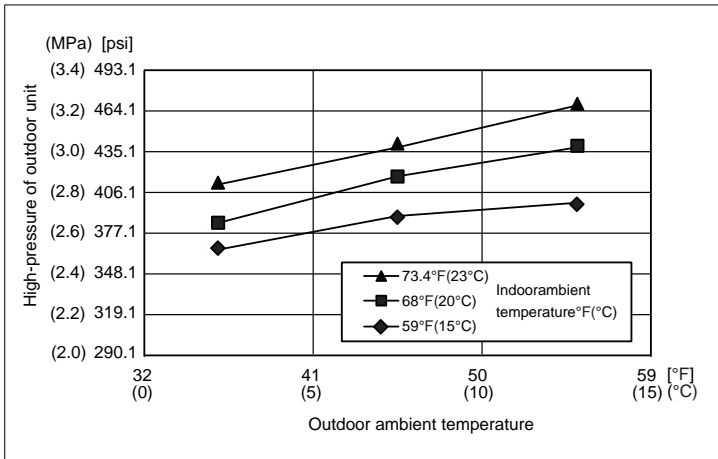

(2) Indoor/Outdoor Temperature - Outdoor Total Electric Current Curve

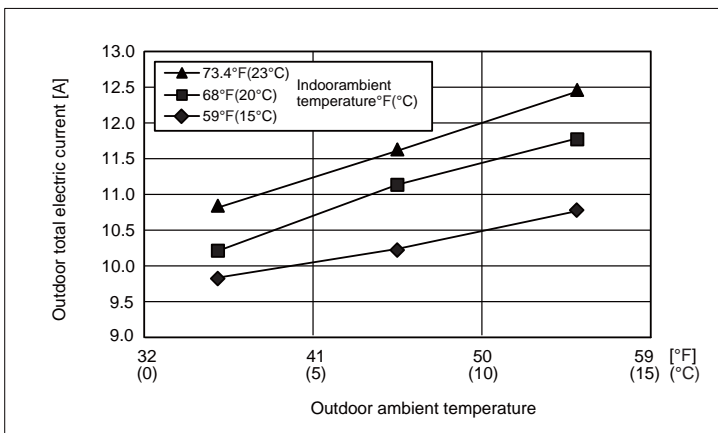

3-3. THERMISTOR RESISTANCE VALUES

Thermistor resistance values

Room temperature thermistor			
Tempe°F	Tempe°C	Resistance(kΩ)	Voltage(V)
32.0	0.0	33.62	1.15
41.0	5.0	25.93	1.39
50.0	10.0	20.17	1.66
59.0	15.0	15.84	1.94
68.0	20.0	12.54	2.22
77.0	25.0	10.00	2.50
86.0	30.0	8.04	2.77
95.0	35.0	6.51	3.03
104.0	40.0	5.30	3.27
113.0	45.0	4.35	3.49
122.0	50.0	3.59	3.68
131.0	55.0	2.98	3.85
140.0	60.0	2.49	4.00
149.0	65.0	2.09	4.14
158.0	70.0	1.76	4.25
167.0	75.0	1.49	4.35
176.0	80.0	1.27	4.44
185.0	85.0	1.09	4.51
194.0	90.0	0.93	4.57
203.0	95.0	0.81	4.63
212.0	100.0	0.70	4.67

Indoor heat exchanger thermistor			
Tempe°F	Tempe°C	Resistance(kΩ)	Voltage(V)
32.0	0.0	176.03	1.10
41.0	5.0	134.23	1.36
50.0	10.0	103.34	1.63
59.0	15.0	80.28	1.92
68.0	20.0	62.91	2.21
77.0	25.0	49.70	2.51
86.0	30.0	39.57	2.79
95.0	35.0	31.74	3.06
104.0	40.0	25.64	3.30
113.0	45.0	20.85	3.53
122.0	50.0	17.06	3.73
131.0	55.0	14.10	3.90
140.0	60.0	11.64	4.05
149.0	65.0	9.69	4.19
158.0	70.0	8.12	4.30
167.0	75.0	6.83	4.40
176.0	80.0	5.78	4.48
185.0	85.0	4.91	4.55
194.0	90.0	4.19	4.61
203.0	95.0	3.59	4.66
212.0	100.0	3.09	4.71

Discharge thermistor			
Tempe°F	Tempe°C	Resistance(kΩ)	Voltage(V)
-22.0	-30.0	1075.95	0.06
-13.0	-25.0	771.62	0.08
-4.0	-20.0	560.69	0.11
5.0	-15.0	412.49	0.15
14.0	-10.0	307.02	0.20
23.0	-5.0	231.05	0.27
32.0	0.0	175.70	0.34
41.0	5.0	134.93	0.44
50.0	10.0	104.59	0.69
59.0	15.0	81.79	0.70
68.0	20.0	64.50	0.84
77.0	25.0	51.27	1.01
86.0	30.0	41.07	1.20
95.0	35.0	33.13	1.41
104.0	40.0	26.91	1.63
113.0	45.0	22.01	1.86
122.0	50.0	18.10	2.09
131.0	55.0	14.98	2.32
140.0	60.0	12.47	2.55
149.0	65.0	10.44	2.77
158.0	70.0	8.78	2.98
167.0	75.0	7.42	3.18
176.0	80.0	6.31	3.37
185.0	85.0	5.38	3.54
194.0	90.0	4.61	3.69
203.0	95.0	3.97	3.83
212.0	100.0	3.43	3.96
221.0	105.0	2.98	4.07
230.0	110.0	2.59	4.17
239.0	115.0	2.26	4.26
248.0	120.0	1.99	4.34

Compressor temperature thermistor			
Tempe°F	Tempe°C	Resistance(kΩ)	Voltage(V)
-22.0	-30.0	1013.11	0.06
-13.0	-25.0	729.09	0.09
-4.0	-20.0	531.56	0.12
5.0	-15.0	392.31	0.16
14.0	-10.0	292.91	0.21
23.0	-5.0	221.09	0.28
32.0	0.0	168.60	0.36
41.0	5.0	129.84	0.46
50.0	10.0	100.91	0.57
59.0	15.0	79.12	0.71
68.0	20.0	62.55	0.86
77.0	25.0	49.84	1.03
86.0	30.0	40.01	1.23
95.0	35.0	32.35	1.43
104.0	40.0	26.34	1.65
113.0	45.0	21.58	1.88
122.0	50.0	17.79	2.11
131.0	55.0	14.75	2.34
140.0	60.0	12.30	2.57
149.0	65.0	10.32	2.79
158.0	70.0	8.70	3.00
167.0	75.0	7.36	3.19
176.0	80.0	6.27	3.37
185.0	85.0	5.36	3.54
194.0	90.0	4.60	3.69
203.0	95.0	3.96	3.82
212.0	100.0	3.43	3.96
221.0	105.0	2.98	4.07
230.0	110.0	2.60	4.17
239.0	115.0	2.27	4.26
248.0	120.0	2.00	4.33

Outdoor heat exchanger thermistor			
Tempe°F	Tempe°C	Resistance(kΩ)	Voltage(V)
-22.0	-30.0	95.58	0.24
-13.0	-25.0	68.90	0.32
-4.0	-20.0	50.31	0.43
5.0	-15.0	37.19	0.57
14.0	-10.0	27.81	0.73
23.0	-5.0	21.02	0.92
32.0	0.0	16.05	1.14
41.0	5.0	12.38	1.39
50.0	10.0	9.63	1.65
59.0	15.0	7.56	1.93
68.0	20.0	5.98	2.21
77.0	25.0	4.77	2.49
86.0	30.0	3.84	2.77
95.0	35.0	3.11	3.02
104.0	40.0	2.53	3.26
113.0	45.0	2.08	3.48
122.0	50.0	1.71	3.68
131.0	55.0	1.42	3.85
140.0	60.0	1.19	4.00
149.0	65.0	1.00	4.13
158.0	70.0	0.84	4.25
167.0	75.0	0.71	4.35
176.0	80.0	0.61	4.43

Outdoor Temperature thermistor			
Tempe°F	Tempe°C	Resistance(kΩ)	Voltage(V)
-22.0	-30.0	224.33	0.73
-13.0	-25.0	159.71	0.97
-4.0	-20.0	115.24	1.25
5.0	-15.0	84.21	1.56
14.0	-10.0	62.28	1.90
23.0	-5.0	46.58	2.26
32.0	0.0	35.21	2.61
41.0	5.0	26.88	2.94
50.0	10.0	20.72	3.25
59.0	15.0	16.12	3.52
68.0	20.0	12.64	3.76
77.0	25.0	10.00	3.97
86.0	30.0	7.97	4.14
95.0	35.0	6.40	4.28
104.0	40.0	5.18	4.41
113.0	45.0	4.21	4.51
122.0	50.0	3.45	4.59
131.0	55.0	2.85	4.65
140.0	60.0	2.36	4.71
149.0	65.0	1.97	4.76
158.0	70.0	1.65	4.79
167.0	75.0	1.39	4.83
176.0	80.0	1.18	4.85



FUJITSU GENERAL LIMITED

3-3-17, Suenaga, Takatsu-ku, Kawasaki 213-8502, Japan