



SPLIT-TYPE AIR CONDITIONERS

Revision A:

- 3. SPECIFICATION has been corrected.

OBH821 is void.

OUTDOOR UNIT

SERVICE MANUAL



No. OBH821
REVISED EDITION-A

Models

MUZ-JP09WA - U1

MUZ-JP12WA - U1

Indoor unit service manual
MSZ-JP•WA Series (OBH820)

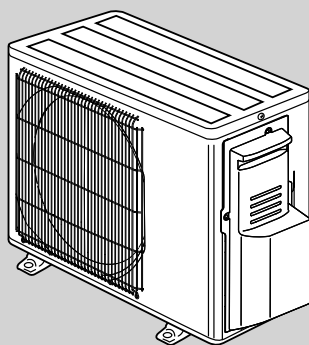

MUZ-JP09WA

CONTENTS

1. TECHNICAL CHANGES	3
2. PART NAMES AND FUNCTIONS	4
3. SPECIFICATION	5
4. OUTLINES AND DIMENSIONS	8
5. WIRING DIAGRAM	9
6. REFRIGERANT SYSTEM DIAGRAM	10
7. DATA	11
8. ACTUATOR CONTROL	18
9. SERVICE FUNCTIONS	19
10. TROUBLESHOOTING	20
11. DISASSEMBLY INSTRUCTIONS	39

PARTS CATALOG (OBB821)

Use the specified refrigerant only

Never use any refrigerant other than that specified.

Doing so may cause a burst, an explosion, or fire when the unit is being used, serviced, or disposed of.

Correct refrigerant is specified in the manuals and on the spec labels provided with our products.

We will not be held responsible for mechanical failure, system malfunction, unit breakdown or accidents caused by failure to follow the instructions.

Revision A:

- 3. SPECIFICATION has been corrected.

1

TECHNICAL CHANGES

MUZ-JP09WA - U1

MUZ-JP12WA - U1

1. New model

MUZ-JP09WA MUZ-JP12WA

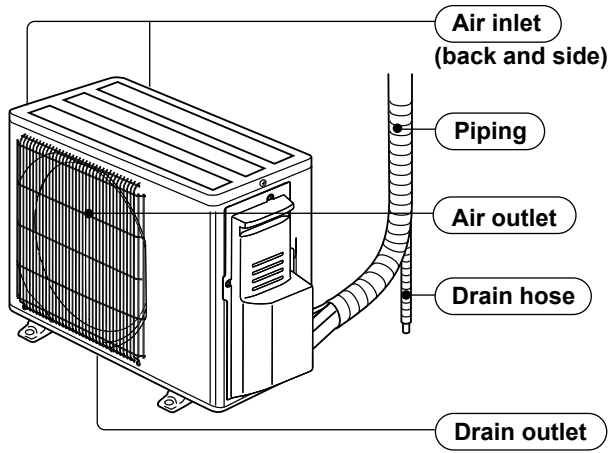

3

SPECIFICATION

Outdoor unit model			MUZ-JP09WA
Capacity Rated (Minimum~Maximum)	Cooling *1	Btu/h	9,000 (3,800 ~ 10,000)
	Heating 47 *1	Btu/h	10,900 (4,500 ~ 11,800)
Capacity Rated (Maximum)	Heating 17 *2	Btu/h	6,700 (7,200)
Power consumption Rated (Minimum~Maximum)	Cooling *1	W	750 (240 - 850)
	Heating 47 *1	W	900 (240 - 1,000)
Power consumption Rated (Maximum)	Heating 17 *2	W	700 (780)
EER *1 [SEER] *3	Cooling		12.0 [17.0]
HSPF IV *4	Heating		9.0
COP	Heating *1		3.55
Power factor	Cooling	%	93
	Heating	%	94
Power supply	V, phase, Hz		115, 1, 60
Max. fuse size (time delay)		A	15
Min. circuit ampacity		A	12
Fan motor	F.L.A	A	0.70
Compressor	Model		KNB073FRXMC
	R.L.A	A	8.8
	L.R.A	A	11.0
	Refrigeration oil	fl oz. (L) (Model)	9.1 (0.27) (FV50S)
Refrigerant control			Linear expansion valve
Sound level *1	Cooling	dB(A)	46
	Heating	dB(A)	50
Airflow High - Med. - Low	Cooling	CFM	1,105 - 1,105 - 1,063
	Heating	CFM	1,282 - 1,105 - 1,105
Fan speed High - Med. - Low	Cooling	rpm	770 - 770 - 740
	Heating	rpm	890 - 770 - 770
Defrost method			Reverse cycle
Dimensions	W	in.	31-1/2
	D	in.	11-1/4
	H	in.	21-5/8
Weight		lb.	73
External finish			Munsell 3Y 7.8/1.1
Refrigerant piping			Not supplied
Refrigerant pipe size (Min. wall thickness)	Liquid	in.	1/4 (0.0315)
	Gas	in.	3/8 (0.0315)
Connection method	Indoor		Flared
	Outdoor		Flared
Between the indoor & outdoor units	Height difference	ft.	40
	Piping length	ft.	65
Refrigerant charge (R410A)			1 lb. 12 oz.

NOTE: Test conditions are based on AHRI 210/240.

*1: Rating conditions (Cooling) — Indoor: 80°FDB, 67°F WB, Outdoor: 95°FDB, (75°F WB)
(Heating) — Indoor: 70°FDB, 60°F WB, Outdoor: 47°FDB, 43°F WB

*2: (Heating) — Indoor: 70°FDB, 60°F WB, Outdoor: 17°FDB, 15°F WB

*3: Test condition (Refer to page 7.)

*4: Test condition (Refer to page 7.)

Outdoor unit model			MUZ-JP12WA
Capacity Rated (Minimum~Maximum)	Cooling *1	Btu/h	12,000 (3,800 ~ 12,200)
	Heating 47 *1	Btu/h	12,200 (4,500 ~ 14,500)
Capacity Rated (Maximum)	Heating 17 *2	Btu/h	7,600 (9,000)
Power consumption Rated (Minimum~Maximum)	Cooling *1	W	1,210 (240 - 1,300)
	Heating 47 *1	W	990 (240 - 1,220)
Power consumption Rated (Maximum)	Heating 17 *2	W	800 (990)
EER *1 [SEER] *3	Cooling		9.9 [17.0]
HSPF IV *4	Heating		9.0
COP	Heating *1		3.61
Power factor	Cooling	%	93
	Heating	%	94
Power supply	V , phase , Hz		115,1, 60
Max. fuse size (time delay)		A	20
Min. circuit ampacity		A	14
Fan motor	F.L.A	A	0.70
Compressor	Model		KNB073FRXMC
	R.L.A	A	10.4
	L.R.A	A	13.0
	Refrigeration oil	fl oz. (L) (Model)	9.1 (0.27) (FV50S)
Refrigerant control			Linear expansion valve
Sound level *1	Cooling	dB(A)	49
	Heating	dB(A)	51
Airflow High - Med. - Low	Cooling	CFM	1,105 - 1,105 - 1,063
	Heating	CFM	1,282 - 1,105 - 1,105
Fan speed High - Med. - Low	Cooling	rpm	770 - 770 - 740
	Heating	rpm	890 - 770 - 770
Defrost method			Reverse cycle
Dimensions	W	in.	31-1/2
	D	in.	11-1/4
	H	in.	21-5/8
Weight	lb.		73
External finish			Munsell 3Y 7.8/1.1
Refrigerant piping			Not supplied
Refrigerant pipe size (Min. wall thickness)	Liquid	in.	1/4 (0.0315)
	Gas	in.	3/8 (0.0315)
Connection method	Indoor		Flared
	Outdoor		Flared
Between the indoor & outdoor units	Height difference	ft.	40
	Piping length	ft.	65
Refrigerant charge (R410A)			1 lb. 12 oz.

NOTE: Test conditions are based on AHRI 210/240.

*1: Rating conditions (Cooling) — Indoor: 80°FDB, 67°FWB, Outdoor: 95°FDB, (75°FWB)
(Heating) — Indoor: 70°FDB, 60°FWB, Outdoor: 47°FDB, 43°FWB

*2: (Heating) — Indoor: 70°FDB, 60°FWB, Outdoor: 17°FDB, 15°FWB

*3: Test condition (Refer to page 7.)

*4: Test condition (Refer to page 7.)

Test condition

※3,※4

ARI	Mode	Test	Indoor air condition (°F)		Outdoor air condition (°F)	
			Dry bulb	Wet bulb	Dry bulb	Wet bulb
	SEER (Cooling)	"A-2" Cooling steady state at rated compressor speed	80	67	95	(75)
		"B-2" Cooling steady state at rated compressor speed	80	67	82	(65)
		"B-1" Cooling steady state at minimum compressor speed	80	67	82	(65)
		"F-1" Cooling steady state at minimum compressor speed	80	67	67	(53.5)
		"E-V" Cooling steady state at intermediate compressor speed ※5	80	67	87	(69)
	HSPF (Heating)	"H1-2" Heating steady state at rated compressor speed	70	60	47	43
		"H3-2" Heating at rated compressor speed	70	60	17	15
		"H0-1" Heating steady state at minimum compressor speed	70	60	62	56.5
		"H1-1" Heating steady state at minimum compressor speed	70	60	47	43
		"H2-V" Heating at intermediate compressor speed ※5	70	60	35	33

※5: at intermediate compressor speed

= ("Rated compressor speed" - "minimum compressor speed") / 3 + "minimum compressor speed".

OPERATING RANGE

(1) POWER SUPPLY

	Rated voltage	Guaranteed voltage (V)
Outdoor unit	115 V 1 phase 60 Hz	Min. 103 115 Max. 127 ----- ----- -----

(2) OPERATION

Mode	Condition	Intake air temperature (°F)			
		Indoor		Outdoor	
		DB	WB	DB	WB
Cooling	Standard temperature	80	67	95	—
	Maximum temperature	90	73	115	—
	Minimum temperature	67	57	14	—
	Maximum humidity	78 %		—	
Heating	Standard temperature	70	60	47	43
	Maximum temperature	80	67	75	65
	Minimum temperature	70	60	-4	-5

MUZ-JP09WA MUZ-JP12WA

Unit: inch

REQUIRED SPACE

*1 4 in. (100 mm) or more when front and sides of the unit are clear

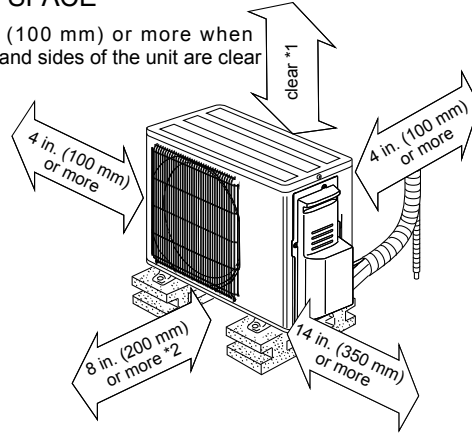

*2 When any 2 sides of left, right and rear of the unit are clear

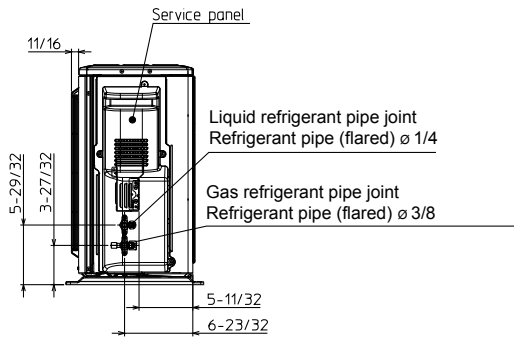
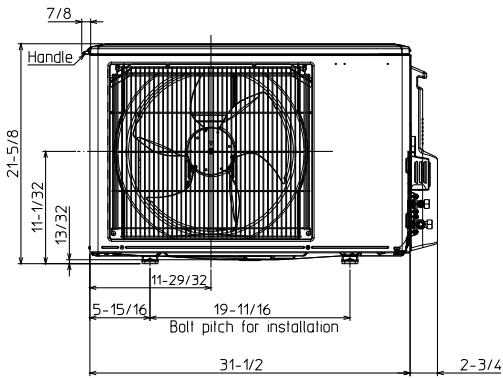
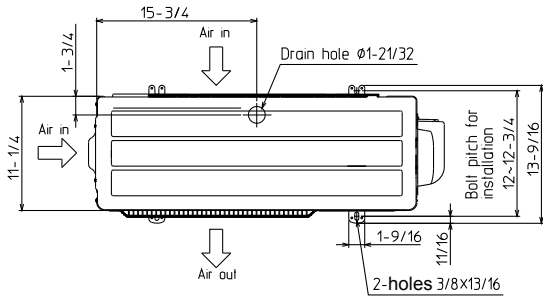

5

WIRING DIAGRAM

MUZ-JP09WA MUZ-JP12WA

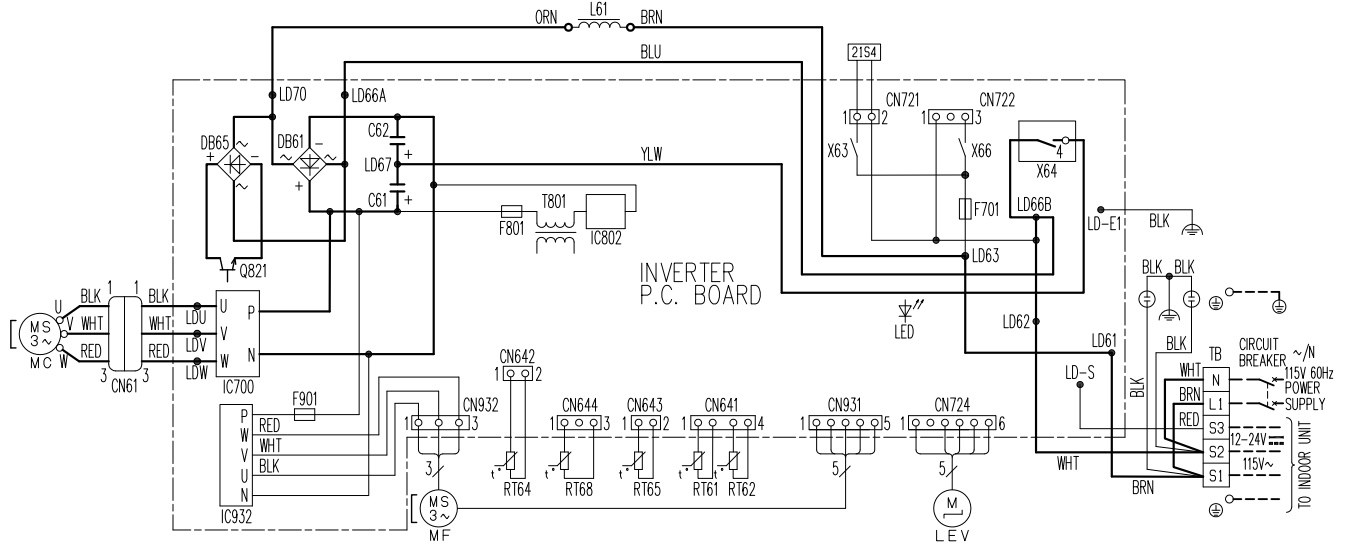

NOTES :

1. About the indoor side electric wiring, refer to the indoor unit electric wiring diagram for servicing.
2. Use copper supply wires.
3. Symbols indicate, :Terminal block :Connector

REMARQUES :

1. Pour le câblage électronique côté intérieur, se reporter au schéma d'entretien du câblage électronique de l'appareil intérieur.
2. Utiliser des fils d'alimentation en cuivre.
3. Les symboles ont les significations suivantes, :Borne :Connecteur

SYMBOL	NAME	SYMBOL	NAME	SYMBOL	NAME
CN61	CONNECTOR	L61	REACTOR	RT68	OUTDOOR HEAT EXCHANGER TEMP. THERMISTOR
C61, C62	SMOOTHING CAPACITOR	MC	COMPRESSOR	TB	TERMINAL BLOCK
DB61, DB65	DIODE MODULE	MF	FAN MOTOR	T801	TRANSFORMER
F701, F801, F901	FUSE (T3, 15A/250V)	Q821	SWITCHING POWER TRANSISTOR	X63, X64, X66	RELAY
IC700, IC932	POWER MODULE	RT61	DEFROST THERMISTOR	21S4	REVERSING VALVE COIL
IC802	POWER DEVICE	RT62	DISCHARGE TEMP. THERMISTOR		
LED	LED	RT64	FIN TEMP. THERMISTOR		
LEV	EXPANSION VALVE COIL	RT65	AMBIENT TEMP. THERMISTOR		

REFRIGERANT SYSTEM DIAGRAM

MUZ-JP09WA MUZ-JP12WA

Unit: Inch (mm)

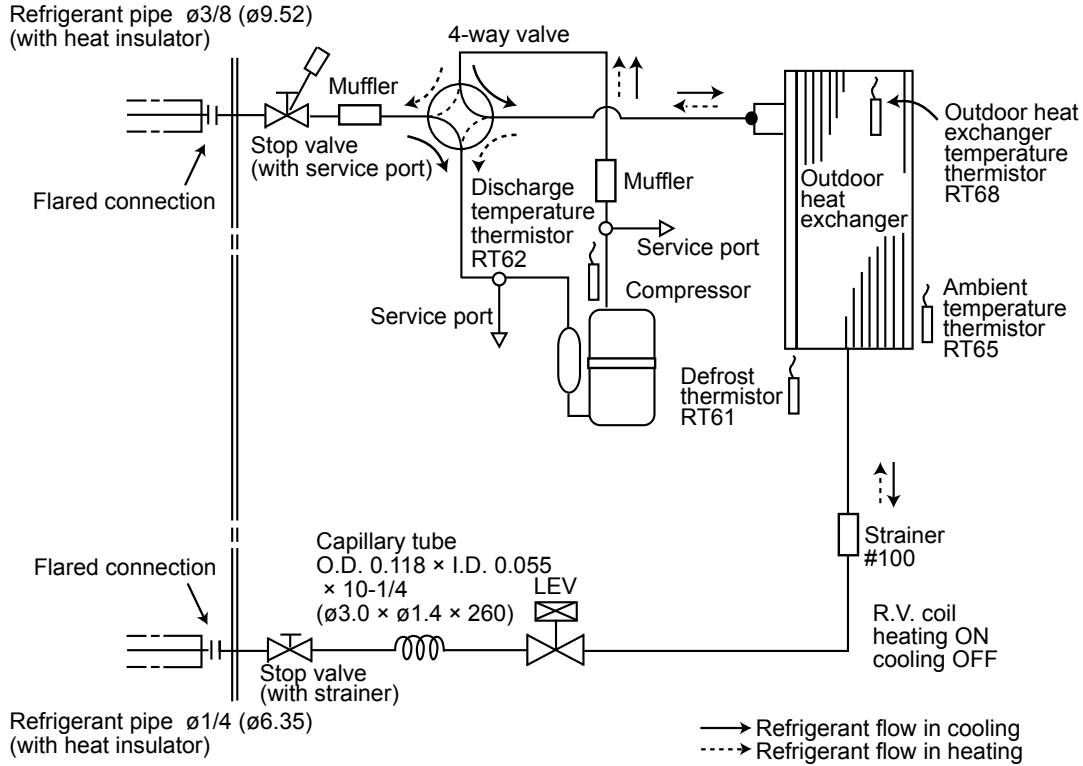

MAX. REFRIGERANT PIPING LENGTH and MAX. HEIGHT DIFFERENCE

Model	Refrigerant piping: ft.		Piping size O.D.: in.	
	Max. Length A	Max. Height difference B	Gas	Liquid
MUZ-JP09WA MUZ-JP12WA	65	40	3/8	1/4

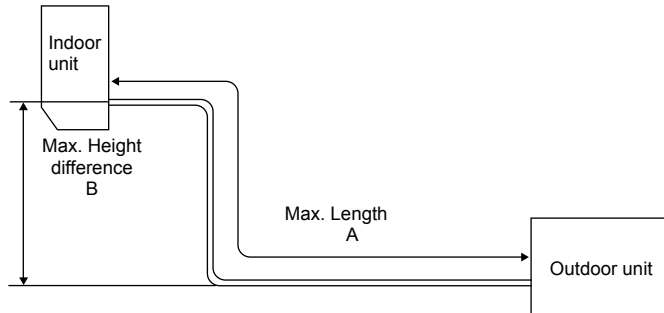

ADDITIONAL REFRIGERANT CHARGE (R410A: oz.)

NOTE: Refrigerant piping exceeding 25 ft. requires additional refrigerant charge according to the calculation.

Model	Outdoor unit precharged	Refrigerant piping length (one way): ft.					
		25	30	40	50	60	65
MUZ-JP09WA MUZ-JP12WA	1 lb. 12 oz.	0	1.08	3.24	5.40	7.56	8.64

Calculation: X oz. = 1.08/5 oz./ft. × (Refrigerant piping length (ft.) - 25)

7

DATA

MUZ-JP09WA MUZ-JP12WA

7-1. PERFORMANCE DATA

1) COOLING CAPACITY

Model	Indoor air IWB (°F)	Outdoor intake air DB temperature (°F)														
		75			85			95			105			115		
		TC	SHC	TPC	TC	SHC	TPC	TC	SHC	TPC	TC	SHC	TPC	TC	SHC	TPC
MUZ-JP09WA	71	11.0	7.6	0.67	10.3	7.1	0.73	9.7	6.6	0.79	9.0	6.2	0.83	8.3	5.7	0.86
	67	10.4	8.6	0.63	9.7	8.0	0.69	9.0	7.4	0.75	8.4	6.9	0.80	7.7	6.3	0.83
	63	9.8	9.4	0.60	9.1	8.7	0.66	8.5	8.1	0.72	7.7	7.3	0.77	7.0	6.7	0.80
MUZ-JP12WA	71	14.7	9.4	1.08	13.7	8.7	1.18	12.9	8.2	1.27	12.0	7.6	1.34	11.0	7.0	1.39
	67	13.9	10.7	1.02	13.0	10.0	1.12	12.0	9.2	1.21	11.2	8.6	1.28	10.3	7.9	1.34
	63	13.1	11.8	0.97	12.1	10.9	1.07	11.3	10.2	1.16	10.3	9.3	1.23	9.4	8.5	1.28

NOTE: 1. IWB : Intake air wet-bulb temperature TC : Total Capacity (x10³ Btu/h)
 SHC : Sensible Heat Capacity (x10³ Btu/h) TPC : Total Power Consumption (kW)
 2. SHC is based on 80°F of indoor Intake air DB temperature.

2) COOLING CAPACITY CORRECTIONS

Model	Refrigerant piping length (one way: ft.)			
	25 (std.)	40	65	100
MUZ-JP09WA MUZ-JP12WA	1.0	0.988	0.967	—

3) HEATING CAPACITY CORRECTIONS

Model	Refrigerant piping length (one way: ft.)			
	25 (std.)	40	65	100
MUZ-JP09WA MUZ-JP12WA	1.0	0.997	0.993	—

4) HEATING CAPACITY

Model	Indoor air IDB (°F)	Outdoor intake air WB temperature (°F)													
		5		15		25		35		43		45		55	
		TC	TPC	TC	TPC	TC	TPC	TC	TPC	TC	TPC	TC	TPC	TC	TPC
MUZ-JP09WA	75	4.8	0.53	6.3	0.67	7.9	0.79	9.4	0.88	10.6	0.92	11.0	0.94	12.4	0.97
	70	5.2	0.51	6.7	0.65	8.2	0.77	9.6	0.86	10.9	0.90	11.2	0.92	12.7	0.95
	65	5.5	0.49	6.9	0.62	8.6	0.74	10.0	0.83	11.2	0.88	11.6	0.89	13.0	0.94
MUZ-JP12WA	75	5.4	0.58	7.1	0.74	8.8	0.87	10.6	0.97	11.9	1.01	12.3	1.03	13.9	1.07
	70	5.8	0.56	7.5	0.71	9.2	0.85	10.8	0.94	12.2	0.99	12.6	1.01	14.2	1.05
	65	6.1	0.53	7.7	0.68	9.6	0.82	11.2	0.92	12.6	0.97	12.9	0.98	14.5	1.03

NOTE: 1. IDB : Intake air dry-bulb temperature
 TC : Total Capacity (x10³ Btu/h) TPC : Total Power Consumption (kW)
 2. Above data is for heating operation without any frost.

How to operate with fixed operational frequency of the compressor

1. Press the EMERGENCY OPERATION switch on the front of the indoor unit, and select either EMERGENCY COOL mode or EMERGENCY HEAT mode before starting to operate the air conditioner.
2. The compressor starts with operational frequency.
3. The fan speed of the indoor unit is High.
4. This operation continues for 30 minutes.
5. In order to release this operation, press the EMERGENCY OPERATION switch or press any button on the remote controller.

7-2. PERFORMANCE CURVE

Cooling

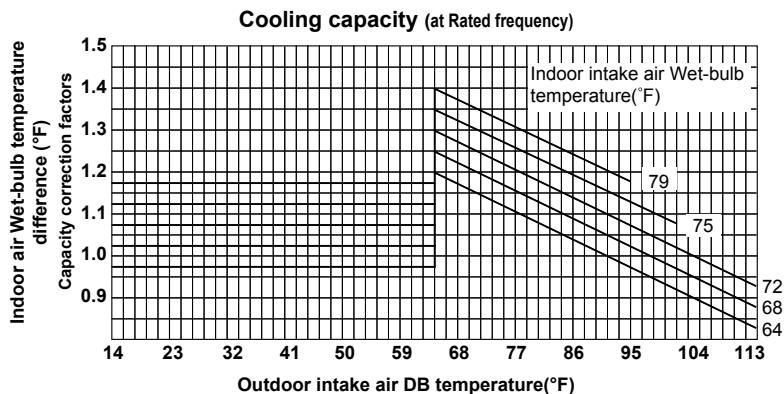

MUZ-JP09WA

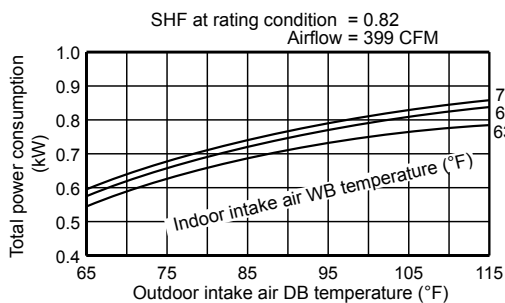

MUZ-JP12WA

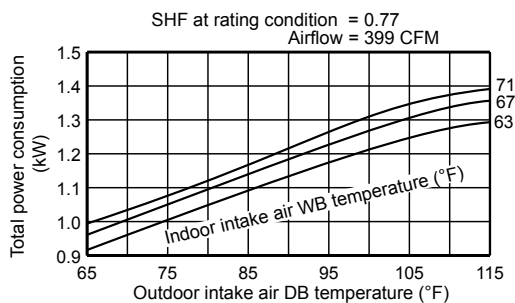

This value of frequency is not the same as the actual frequency in operating. Refer to 7-5 and 7-6 for the relationships between frequency and capacity.

Heating

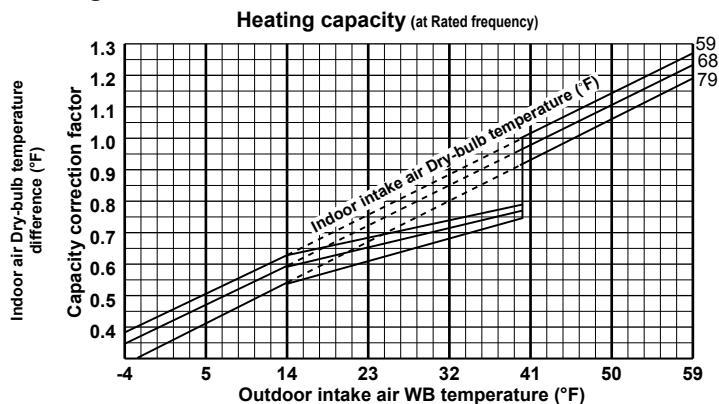

MUZ-JP09WA

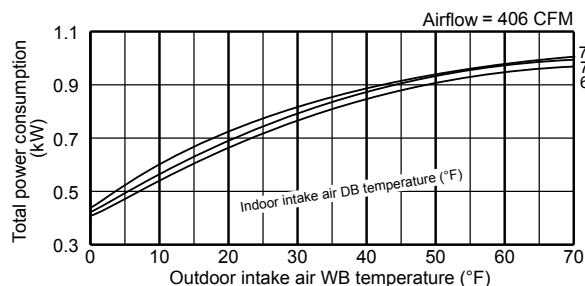

MUZ-JP12WA

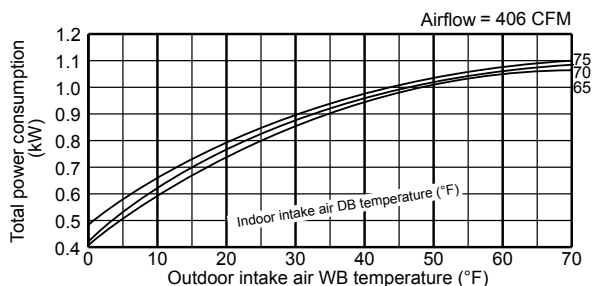

This value of frequency is not the same as the actual frequency in operating. Refer to 7-5 and 7-6 for the relationships between frequency and capacity.

7-3. CONDENSING PRESSURE

Cooling

Data are based on the condition of indoor humidity 50 %.

Air flow should be set to High speed.

MUZ-JP09WA

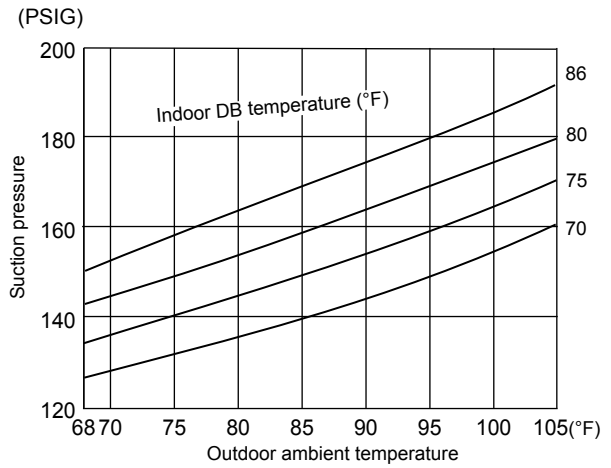
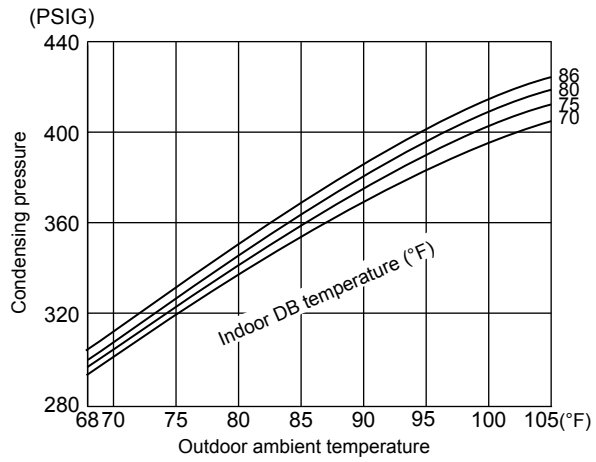

MUZ-JP12WA

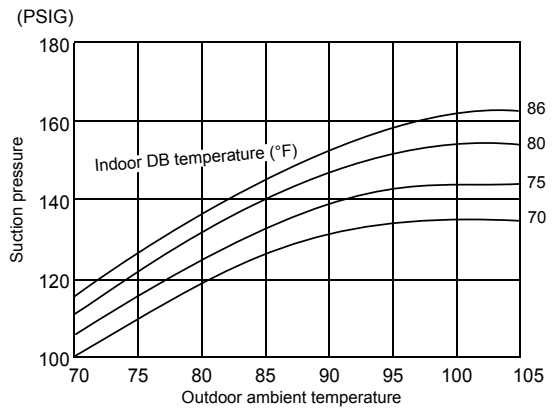
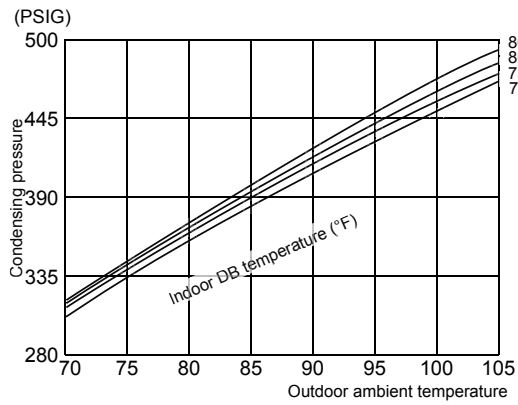

Heating

Data are based on the condition of outdoor humidity 75%.

Air flow should be set to High speed.

Data are for heating operation without any frost.

MUZ-JP09WA MUZ-JP12WA

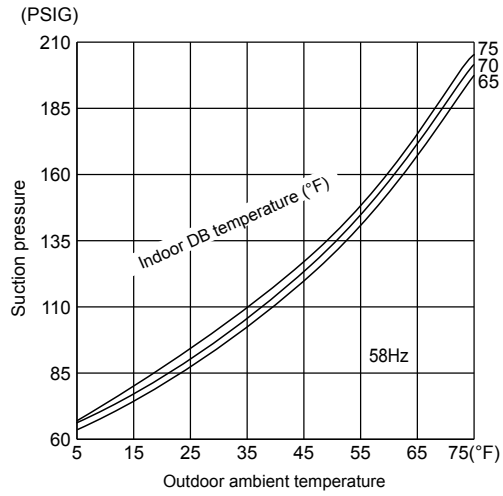
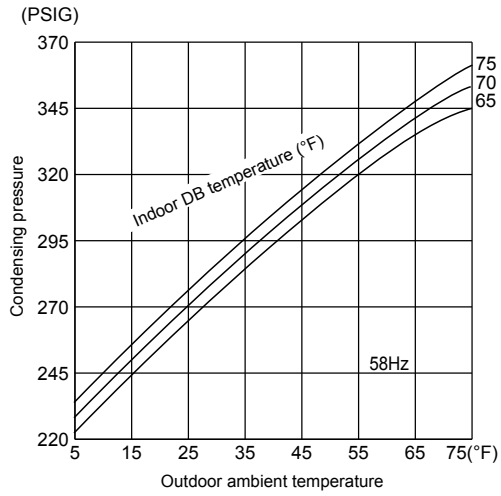

7-4. STANDARD OPERATION DATA

Model			MSZ-JP09WA		
Item		Unit	Cooling	Heating	
Total	Capacity	Btu/h	9,000	10,900	
	SHF	—	0.82	—	
	Input	kW	0.750	0.900	
	Rated frequency	Hz	61.0	79.0	
Electrical circuit	Indoor unit		MSZ-JP09WA		
	Power supply	V, phase, Hz	115, 1, 60		
	Input	kW	0.022	0.023	
	Fan motor current	A	0.37	0.38	
	Outdoor unit		MUZ-JP09WA		
	Power supply	V, phase, Hz	115, 1, 60		
	Input	kW	0.728	0.877	
	Comp. current	A	6.15	7.38	
	Fan motor current	A	0.48	0.54	
	Refrigerant circuit	Condensing pressure	PSIG	384	331
Suction pressure		PSIG	152	102	
Discharge temperature		°F	151	155	
Condensing temperature		°F	113	101	
Suction temperature		°F	58	41	
Comp. shell bottom temperature		°F	146	149	
Ref. pipe length		ft.	25		
Refrigerant charge (R410A)			1 lb. 12 oz.		
Indoor unit	Intake air temperature	DB	°F	80	70
		WB	°F	67	60
	Discharge air temperature	DB	°F	60	97
		WB	°F	58	—
	Fan speed (High)	rpm	1,020	1,040	
Airflow (High)	CFM	367 (Wet)	413		
Outdoor unit	Intake air temperature	DB	°F	95	47
		WB	°F	—	43
	Fan speed	rpm	770	850	
	Airflow	CFM	1,105	1,225	

7-4. STANDARD OPERATION DATA

Model			MSZ-JP12WA		
Item		Unit	Cooling	Heating	
Total	Capacity	Btu/h	12,000	12,200	
	SHF	—	0.77	—	
	Input	kW	1.210	0.990	
	Rated frequency	Hz	91.0	90.0	
Electrical circuit	Indoor unit		MSZ-JP12WA		
	Power supply	V, phase, Hz	115, 1, 60		
	Input	kW	0.022	0.023	
	Fan motor current	A	0.37	0.38	
	Outdoor unit		MUZ-JP12WA		
	Power supply	V, phase, Hz	115, 1, 60		
	Input	kW	1.188	0.967	
	Comp. current	A	10.35	8.18	
	Fan motor current	A	0.48	0.54	
Refrigerant circuit	Condensing pressure	PSIG	429	347	
	Suction pressure	PSIG	135	99	
	Discharge temperature	°F	180	165	
	Condensing temperature	°F	120	104	
	Suction temperature	°F	60	41	
	Comp. shell bottom temperature	°F	174	157	
	Ref. pipe length	ft.	25		
	Refrigerant charge (R410A)		1 lb. 12 oz.		
Indoor unit	Intake air temperature	DB	°F	80	70
		WB	°F	67	60
	Discharge air temperature	DB	°F	56	108
		WB	°F	55	—
	Fan speed (High)	rpm	1,020	1,040	
Airflow (High)	CFM	367 (Wet)	413		
Outdoor unit	Intake air temperature	DB	°F	95	47
		WB	°F	—	43
	Fan speed	rpm	770	850	
	Airflow	CFM	1,105	1,225	

7-5. CAPACITY AND INPUT CORRECTION BY INVERTER OUTPUT FREQUENCY

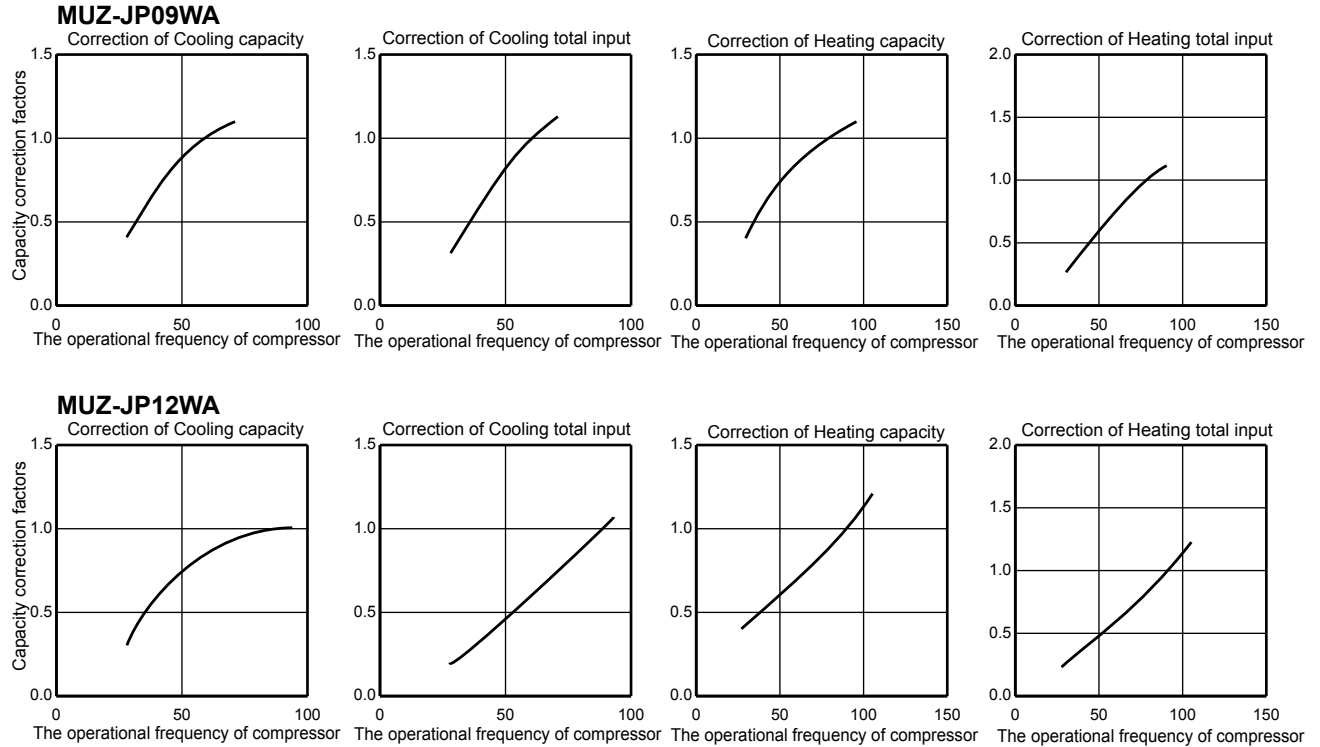

7-6. HOW TO OPERATE FIXED-FREQUENCY OPERATION (Test run operation)

1. Press EMERGENCY OPERATION switch to start COOL or HEAT mode (COOL: Press once, HEAT: Press twice).
2. Test run operation starts and continues to operate for 30 minutes.
3. Compressor operates at rated frequency in COOL mode or 58 Hz in HEAT mode.
4. Indoor fan operates at High speed.
5. After 30 minutes, test run operation finishes and EMERGENCY OPERATION starts (operation frequency of compressor varies).
6. To cancel test run operation (EMERGENCY OPERATION), press EMERGENCY OPERATION switch or any button on remote controller.

MUZ-JP09WA MUZ-JP12WA

8-1. OUTDOOR FAN MOTOR CONTROL

The fan motor turns ON/OFF, interlocking with the compressor.

[ON] The fan motor turns ON 5 seconds before the compressor starts up.

[OFF] The fan motor turns OFF 15 seconds after the compressor has stopped running.

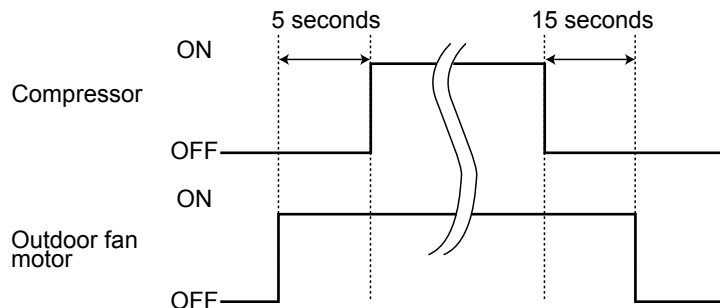

8-2. R.V. COIL CONTROL

Heating ON

Cooling OFF

Dry OFF

NOTE: The 4-way valve reverses for 5 seconds right before start-up of the compressor.

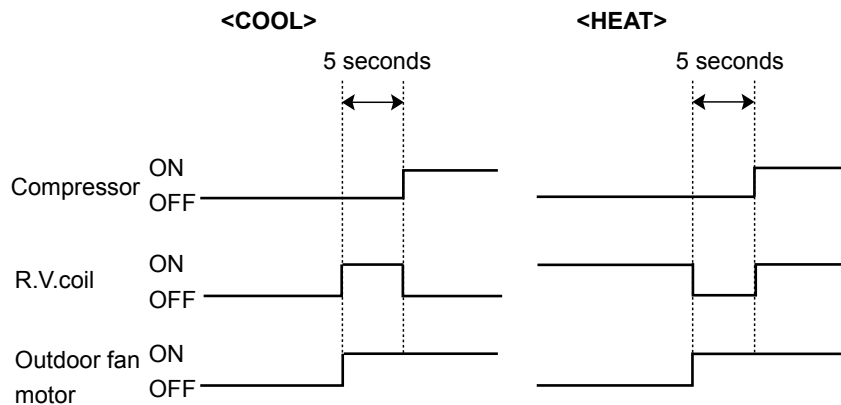

8-3. RELATION BETWEEN MAIN SENSOR AND ACTUATOR

Sensor	Purpose	Actuator				
		Compressor	LEV	Outdoor fan motor	R.V. coil	Indoor fan motor
Discharge temperature thermistor	Protection	○	○			
Indoor coil temperature thermistor	Cooling: Coil frost prevention	○				
	Heating: High pressure protection	○	○			
Defrost thermistor	Heating: Defrosting	○	○	○	○	○
Fin temperature thermistor	Protection	○		○		
Ambient temperature thermistor	Cooling: Low ambient temperature operation	○	○	○		
	Heating: Defrosting (Heater)					
Outdoor heat exchanger temperature thermistor	Cooling: Low ambient temperature operation	○	○	○		
	Cooling: High pressure protection	○	○	○		

MUZ-JP09WA MUZ-JP12WA**9-1. CHANGE IN DEFROST SETTING****Changing defrost finish temperature**

<JS> To change the defrost finish temperature, cut/solder the JS wire of the outdoor inverter P.C. board (Refer to 10-6.1.).

Jumper		Defrost finish temperature
		MUZ-JP09/12
JS	Soldered (Initial setting)	50°F (10°C)
	None (Cut)	55.4°F (13°C)

9-2. PRE-HEAT CONTROL SETTING

When moisture gets into the refrigerant cycle, it may interfere with the start-up of the compressor at low outside temperature. The pre-heat control prevents this interference. The pre-heat control turns ON when the discharge temperature thermostat is 68°F (20°C) or below. When the pre-heat control turns ON, the compressor is energized. (About 50 W)

Pre-heat control setting

<JK>

ON: To activate the pre-heat control, cut JK wire of the inverter P.C. board.

OFF: To deactivate the pre-heat control, solder JK wire of the inverter P.C. board.

(Refer to 10-6.1)

Jumper		Pre-heat control setting
JK	Soldered	Deactivated (Factory setting)
	Cut	Activated

NOTE: When the inverter P.C. board is replaced, check the jumper wires, and cut/solder them if necessary.

MUZ-JP09WA MUZ-JP12WA**10-1. CAUTIONS ON TROUBLESHOOTING****1. Before troubleshooting, check the following**

- 1) Check the power supply voltage.
- 2) Check the indoor/outdoor connecting wire for miswiring.

2. Take care of the following during servicing

- 1) Before servicing the air conditioner, be sure to turn OFF the main unit first with the remote controller, then after confirming the horizontal vane is closed, turn off the breaker and/or disconnect the power plug.
- 2) Be sure to turn OFF the power supply before removing the front panel, the cabinet, the top panel, and the electronic control P.C. board.
- 3) When removing the electrical parts, be careful of the residual voltage of smoothing capacitor.
- 4) When removing the electronic control P.C. board, hold the edge of the board with care NOT to apply stress on the components.

<Incorrect>

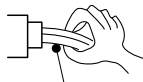
**Lead wiring**

<Correct>

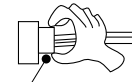
**Connector housing**

- 5) When connecting or disconnecting the connectors, hold the connector housing. DO NOT pull the lead wires.

3. Troubleshooting procedure

- 1) Check if the OPERATION INDICATOR lamp on the indoor unit is blinking on and off to indicate an abnormality. To make sure, check how many times the OPERATION INDICATOR lamp is blinking on and off before starting service work. (See the service manual of the indoor unit for a description of those failure codes.)
- 2) Before servicing, check that the connector and terminal are connected properly.
- 3) When the electronic control P.C. board seems to be defective, check the copper foil pattern for disconnection and the components for bursting and discoloration.
- 4) Refer to 10-2 and 10-3.

10-2. FAILURE MODE RECALL FUNCTION

Outline of the function

This air conditioner can memorize the abnormal condition which has occurred once.

Even though LED indication listed on the troubleshooting check table (10-3.) disappears, the memorized failure details can be recalled.

1. Flow chart of failure mode recall function for the indoor/outdoor unit

Operational procedure

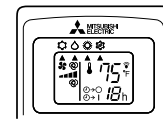
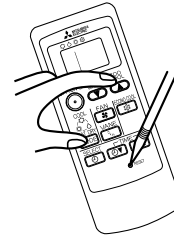
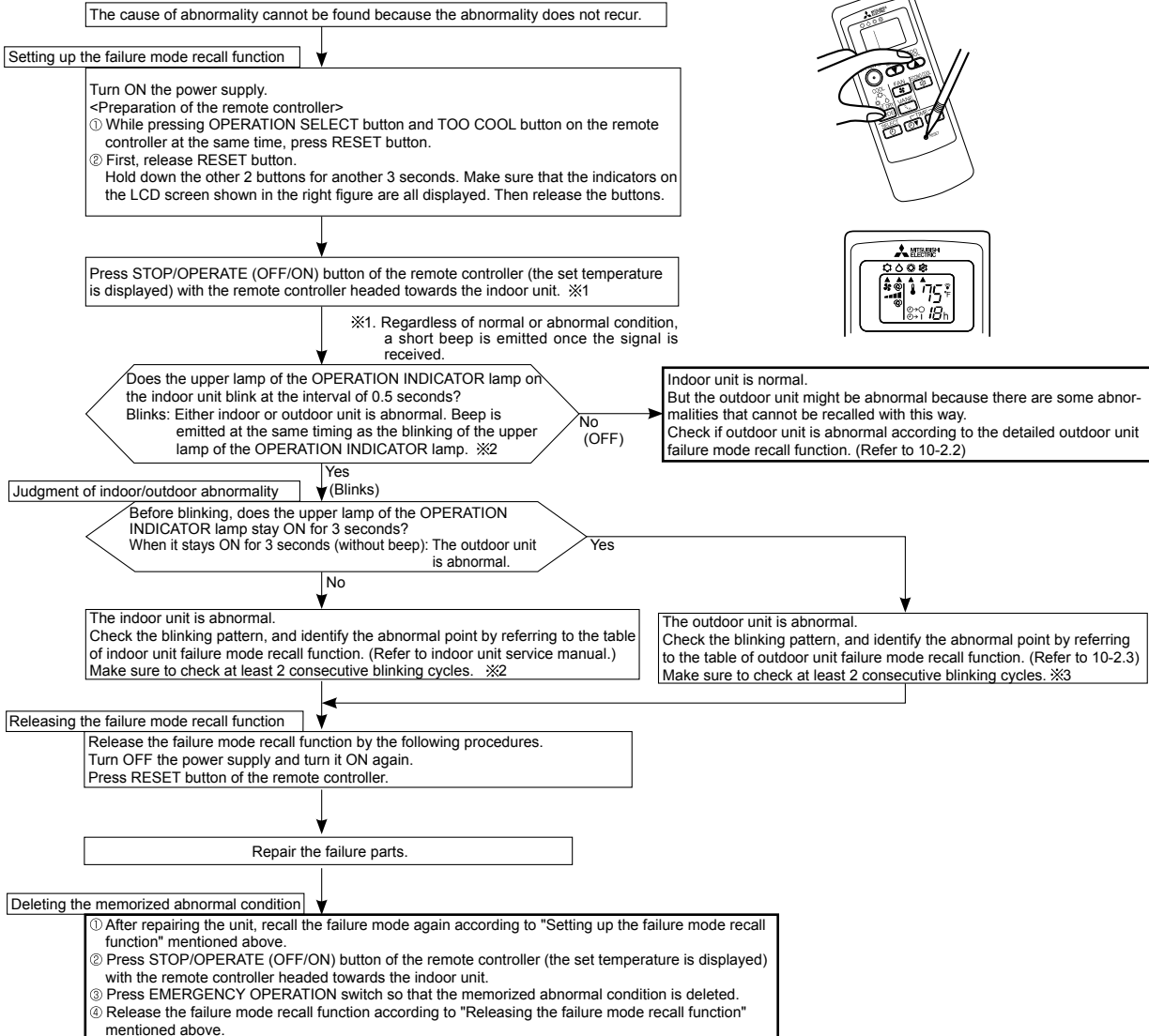

- NOTE:** 1. Make sure to release the failure mode recall function after it is set up, otherwise the unit cannot operate properly.
 2. If the abnormal condition is not deleted from the memory, the last abnormal condition is kept memorized.

※2. Blinking pattern when the indoor unit is abnormal:

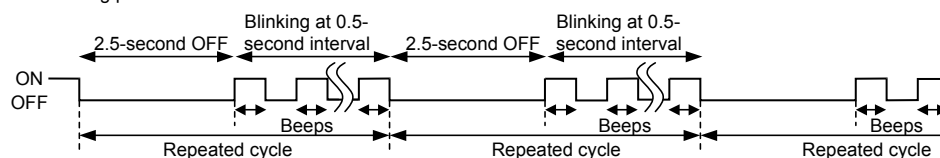

※3. Blinking pattern when the outdoor unit is abnormal:

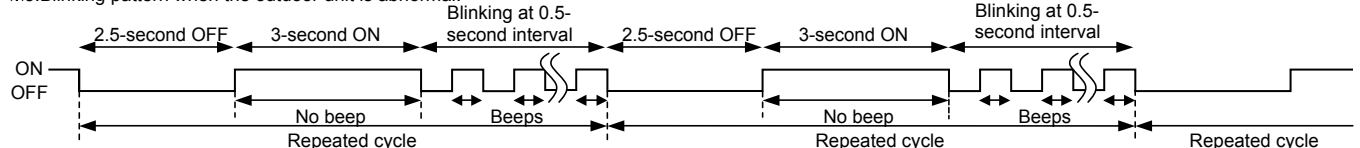

2. Flow chart of the detailed outdoor unit failure mode recall function

Operational procedure

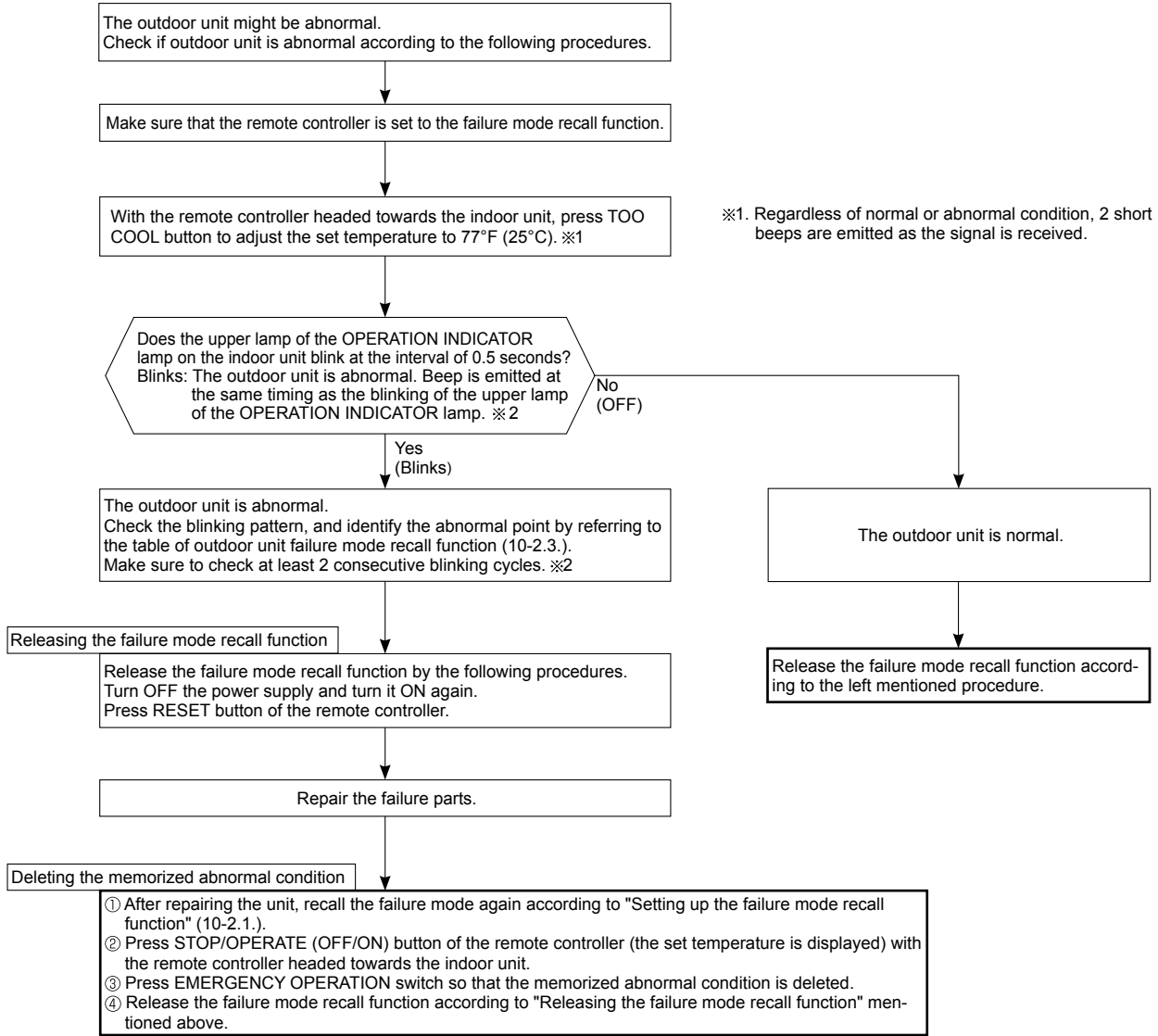

NOTE: 1. Make sure to release the failure mode recall function after it is set up, otherwise the unit cannot operate properly.
2. If the abnormal condition is not deleted from the memory, the last abnormal condition is kept memorized.

※2. Blinking pattern when outdoor unit is abnormal:

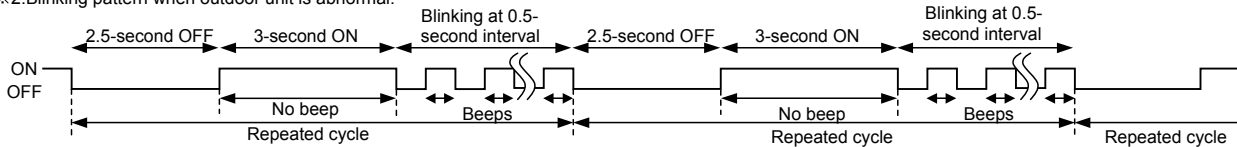

3. Table of outdoor unit failure mode recall function

NOTE: Blinking patterns of this mode differ from the ones of TROUBLESHOOTING CHECK TABLE (10-3.).

MUZ-JP09WA MUZ-JP12WA

OPERATION INDICATOR upper lamp (Indoor unit)	Abnormal point (Failure mode / protection)	LED indication (Outdoor P.C. board)	Condition	Remedy	Indoor/ outdoor unit failure mode recall function	Outdoor unit failure mode recall function
OFF	None (Normal)	—	—	—	—	—
2-time blink 2.5 seconds OFF	Outdoor power system	—	Overcurrent protection cut-out operates 3 consecutive times within 1 minute after the compressor gets started.	<ul style="list-style-type: none"> •Reconnect connectors. •Refer to 10-5.㉔"How to check inverter/compressor". •Check the stop valve. 	○	○
3-time blink 2.5 seconds OFF	Discharge temperature thermistor	1-time blink every 2.5 seconds	Thermistor shorts or opens during compressor running.	<ul style="list-style-type: none"> •Refer to 10-5.㉔"Check of outdoor thermistors". Defective outdoor thermistors can be identified by checking the blinking pattern of LED. 	○	○
	Defrost thermistor					
	Fin temperature thermistor	3-time blink 2.5 seconds OFF				
	P.C. board temperature thermistor	4-time blink 2.5 seconds OFF				
	Ambient temperature thermistor	2-time blink 2.5 seconds OFF				
4-time blink 2.5 seconds OFF	Overcurrent	11-time blink 2.5 seconds OFF	Large current flows into intelligent power module/ power module *1.	<ul style="list-style-type: none"> •Reconnect compressor connector. •Refer to 10-5.㉔"How to check inverter/compressor". •Check the stop valve. 	—	○
	Compressor synchronous abnormality (Compressor start-up failure protection)	12-time blink 2.5 seconds OFF	Waveform of compressor current is distorted.	<ul style="list-style-type: none"> •Reconnect compressor connector. •Refer to 10-5.㉔"How to check inverter/compressor". 	—	○
5-time blink 2.5 seconds OFF	Discharge temperature	—	Temperature of discharge temperature thermistor exceeds 241°F (116°C), compressor stops. Compressor can restart if discharge temperature thermistor reads 212°F (100°C) or less 3 minutes later.	<ul style="list-style-type: none"> •Check the refrigerant circuit and the refrigerant amount. •Refer to 10-5.㉔"Check of LEV". 	—	○
6-time blink 2.5 seconds OFF	High pressure	—	Temperature of indoor coil thermistor exceeds 158°F (70°C) in HEAT mode. Temperature of outdoor heat exchanger temperature thermistor exceeds 158°F (70°C) in COOL mode.	<ul style="list-style-type: none"> •Check the refrigerant circuit and the refrigerant amount. •Check the stop valve. 	—	○
7-time blink 2.5 seconds OFF	Fin temperature/ P.C. board temperature	7-time blink 2.5 seconds OFF	Temperature of fin temperature thermistor on the inverter P.C. board exceeds 167 - 176°F (75 - 80°C), or temperature of P.C. board temperature thermistor on the inverter P.C. board exceeds 158 - 167°F (70 - 75°C).	<ul style="list-style-type: none"> •Check around the outdoor unit. •Check the outdoor unit air passage. •Refer to 10-5.㉔"Check of outdoor fan motor". 	—	○
8-time blink 2.5 seconds OFF	Outdoor fan motor	—	Outdoor fan has stopped 3 times in a row within 30 seconds after outdoor fan start-up.	<ul style="list-style-type: none"> •Refer to 10-5.㉔"Check of outdoor fan motor". •Refer to 10-5.㉔"Check of inverter P.C. board". 	—	○
9-time blink 2.5 seconds OFF	Nonvolatile memory data	5-time blink 2.5 seconds OFF	Nonvolatile memory data cannot be read properly.	<ul style="list-style-type: none"> •Replace the inverter P.C. board. 	○	○
10-time blink 2.5 seconds OFF	Discharge temperature	—	Temperature of discharge temperature thermistor has been 122°F (50°C) or less for 20 minutes.	<ul style="list-style-type: none"> •Refer to 10-5.㉔"Check of LEV". •Check the refrigerant circuit and the refrigerant amount. 	—	○

NOTE: Blinking patterns of this mode differ from the ones of TROUBLESHOOTING CHECK TABLE (10-3.).

OPERATION INDICATOR upper lamp (Indoor unit)	Abnormal point (Failure mode / protection)	LED indication (Outdoor P.C. board)	Condition	Remedy	Indoor/ outdoor unit failure mode recall function	Outdoor unit failure mode recall function
11-time blink 2.5 seconds OFF	Bus-bar voltage (DC)	8-time blink 2.5 seconds OFF	Bus-bar voltage of inverter cannot be detected normally.	•Refer to 10-5. ④ "How to check inverter/ compressor".	—	○
	Each phase current of compressor	9-time blink 2.5 seconds OFF	Each phase current of compressor cannot be detected normally.			
12-time blink 2.5 seconds OFF	Overcurrent Compressor open-phase	10-time blink 2.5 seconds OFF	Large current flows into intelligent power module (IPM)/power module (IPM) *1. The open-phase operation of compressor is detected. The interphase short circuit occurs in the output of the intelligent power module (IPM)/power module (IPM) *1. The compressor winding shorts circuit.	•Reconnect compressor connector. •Refer to 10-5. ④ "How to check inverter/ compressor".	—	○
13-time blink 2.5 seconds OFF	Abnormal of wrong voltage power supply connected.	—	When a 200 V power supply is connected to the 115 V model, outdoor unit is not able to operate.	•Check the power supply voltage.	○	○
14-time blink 2.5 seconds OFF	Stop valve (Closed valve)	14-time blink 2.5 seconds OFF	Closed valve is detected by compressor current.	•Check the stop valve	○	○
	4-way valve/ Pipe temperature	16-time blink 2.5 seconds OFF	The 4-way valve does not work properly. The indoor coil thermistor detects an abnormal temperature.	•Check the 4-way valve. •Replace the inverter P.C. board.		
	Outdoor refrigerant system abnormality	1-time blink 2.5 seconds OFF	A closed valve and air trapped in the refrigerant circuit are detected based on the temperature sensed by the indoor and outdoor thermistors and the current of the compressor.	•Check for a gas leak in a connecting piping etc. •Check the stop valve. •Refer to 10-5. ④ "Check of outdoor refrigerant circuit".		

10-3. TROUBLESHOOTING CHECK TABLE

No.	Symptom	LED indication	Abnormal point/ Condition	Condition	Remedy
1	Outdoor unit does not operate.	1-time blink every 2.5 seconds	Outdoor power system	Overcurrent protection cut-out operates 3 consecutive times within 1 minute after the compressor gets started.	<ul style="list-style-type: none"> •Reconnect connector of compressor. •Refer to 10-5.㉔ "How to check inverter/compressor". •Check stop valve.
2			Outdoor thermistors	Discharge temperature thermistor, fin temperature thermistor, defrost thermistor, P.C. board temperature thermistor, outdoor heat exchanger temperature thermistor or ambient temperature thermistor shorts or opens during compressor running.	•Refer to 10-5.㉓ "Check of outdoor thermistors".
3			Outdoor control system	Nonvolatile memory data cannot be read properly. (The upper lamp of the OPERATION INDICATOR lamp on the indoor unit lights up or blinks 7-time.)	•Replace inverter P.C. board.
4		6-time blink 2.5 seconds OFF	Serial signal	The communication fails between the indoor and outdoor unit for 3 minutes.	•Refer to 10-5.㉒ "How to check miswiring and serial signal error."
5		9-time blink 2.5 seconds OFF	Abnormal of wrong voltage power supply connected	When a 200 V power supply is connected to the 115 V model, outdoor unit is not able to operate.	•Check the power supply voltage.
6		11-time blink 2.5 seconds OFF	Stop valve/ Closed valve	Closed valve is detected by compressor current.	•Check stop valve.
7		16-time blink 2.5 seconds OFF	4-way valve/ Pipe temperature	The 4-way valve does not work properly. The indoor coil thermistor detects an abnormal temperature.	<ul style="list-style-type: none"> •Refer to 10-5.㉑ "Check of R.V. coil". •Replace the inverter P.C. board.
8		17-time blink 2.5 seconds OFF	Outdoor refrigerant system abnormality	A closed valve and air trapped in the refrigerant circuit are detected based on the temperature sensed by the indoor and outdoor thermistors and the current of the compressor.	<ul style="list-style-type: none"> •Check for a gas leak in a connecting piping etc. •Check the stop valve. •Refer to 10-5.㉒ "Check of outdoor refrigerant circuit".
9	'Outdoor unit stops and restarts 3 minutes later' is repeated.	2-time blink 2.5 seconds OFF	Overcurrent protection	Large current flows into the power module (IC700). ※ When overcurrent protection occurs within 10 seconds after compressor starts, compressor restarts after 15 seconds.	<ul style="list-style-type: none"> •Reconnect connector of compressor. •Refer to 10-5.㉔ "How to check inverter/compressor". •Check stop valve.
10			3-time blink 2.5 seconds OFF	Discharge temperature overheat protection	Temperature of discharge temperature thermistor exceeds 241°F (116°C), compressor stops. Compressor can restart if discharge temperature thermistor reads 212°F (100°C) or less 3 minutes later.
11		4-time blink 2.5 seconds OFF	Fin temperature / P.C. board temperature thermistor overheat protection	Temperature of the fin temperature thermistor on the heat sink exceeds 167 - 176°F (75 - 80°C) or temperature of P.C. board temperature thermistor on the inverter P.C. board exceeds 158 - 167°F (70 - 75°C).	<ul style="list-style-type: none"> •Check around outdoor unit. •Check outdoor unit air passage. •Refer to 10-5.㉑ "Check of outdoor fan motor".
12		5-time blink 2.5 seconds OFF	High pressure protection	Indoor coil thermistor exceeds 158°F (70°C) in HEAT mode. Defrost thermistor exceeds 158°F (70°C) in COOL mode.	<ul style="list-style-type: none"> •Check refrigerant circuit and refrigerant amount. •Check stop valve.
13		8-time blink 2.5 seconds OFF	Compressor synchronous abnormality	The waveform of compressor current is distorted.	<ul style="list-style-type: none"> •Reconnect connector of compressor. •Refer to 10-5.㉔ "How to check inverter/compressor".
14		10-time blink 2.5 seconds OFF	Outdoor fan motor	Outdoor fan has stopped 3 times in a row within 30 seconds after outdoor fan start-up.	<ul style="list-style-type: none"> •Refer to 10-5.㉑ "Check of outdoor fan motor." •Refer to 10-5.㉒ "Check of inverter P.C. board."
15		12-time blink 2.5 seconds OFF	Each phase current of compressor	Each phase current of compressor cannot be detected normally.	•Refer to 10-5.㉔ "How to check inverter/compressor".
16		13-time blink 2.5 seconds OFF	Bus-bar voltage (DC)	Bus-bar voltage of inverter cannot be detected normally.	•Refer to 10-5.㉔ "How to check inverter/compressor".

- NOTE:** 1. The location of LED is illustrated at the right figure. Refer to 10-6.1.
 2. LED is lighted during normal operation.
 3. Blinking patterns of this mode differ from the ones of the failure recall mode.

The blinking frequency shows the number of times the LED blinks after every 2.5-second OFF.
 (Example) When the blinking frequency is "2".

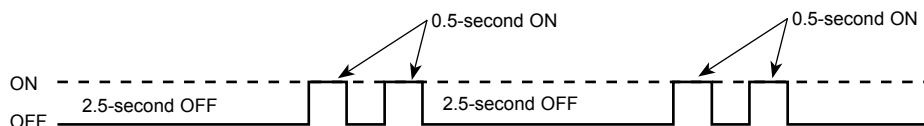

Inverter P.C. board
MUZ-JP09/12WA

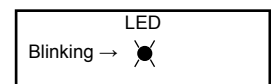



No.	Symptom	LED indication	Abnormal point/ Condition	Condition	Remedy	
17	Outdoor unit operates.	1-time blink 2.5 seconds OFF	Frequency drop by current protection	Current from power outlet is nearing Max. fuse size.	The unit is normal, but check the following. •Check if indoor filters are clogged. •Check if refrigerant is short. •Check if indoor/outdoor unit air circulation is short cycled.	
18		3-time blink 2.5 seconds OFF	Frequency drop by high pressure protection	Temperature of indoor coil thermistor exceeds 131 °F (55°C) in HEAT mode, compressor frequency lowers.		
			Frequency drop by defrosting in COOL mode	Indoor coil thermistor reads 46°F (8°C) or less in COOL mode, compressor frequency lowers.		
19		4-time blink 2.5 seconds OFF	Frequency drop by discharge temperature protection	Temperature of discharge temperature thermistor exceeds 232°F (111°C), compressor frequency lowers.		•Check refrigerant circuit and refrigerant amount. •Refer to 10-5.Ⓚ "Check of LEV". •Refer to 10-5.ⓐ "Check of outdoor thermistors".
20		5-time blink 2.5 seconds OFF	Outside temperature thermistor protection	When the outside temperature thermistor shorts or opens, protective operation without that thermistor is performed.		•Refer to 10-5. ⓐ Check of outdoor thermistors.
21		7-time blink 2.5 seconds OFF	Low discharge temperature protection	Temperature of discharge temperature thermistor has been 122°F (50°C) or less for 20 minutes.		•Refer to 10-5.Ⓚ "Check of LEV". •Check refrigerant circuit and refrigerant amount.
22		8-time blink 2.5 seconds OFF	PAM protection PAM: Pulse Amplitude Modulation	The overcurrent flows into PFC (Power factor correction: IC820) or the bus-bar voltage reaches 394 V or more, PAM stops and restarts.		This is not malfunction. PAM protection will be activated in the following cases: 1 Instantaneous power voltage drop. (Short time power failure) 2 When the power supply voltage is high.
	Zero cross detecting circuit		Zero cross signal for PAM control cannot be detected.			
23	9-time blink 2.5 seconds OFF	Inverter check mode	The connector of compressor is disconnected, inverter check mode starts.	•Check if the connector of the compressor is correctly connected. Refer to 10-5.Ⓐ "How to check inverter/compressor".		

- NOTE:** 1. The location of LED is illustrated at the right figure. Refer to 10-6.1.
 2. LED is lighted during normal operation.
 3. Blinking patterns of this mode differ from the ones of the failure recall mode.

The blinking frequency shows the number of times the LED blinks after every 2.5-second OFF.
 (Example) When the blinking frequency is "2".

Inverter P.C. board
MUZ-JP09/12WA

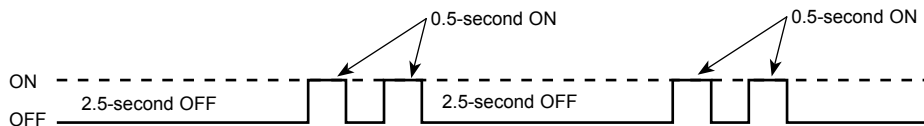
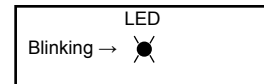

10-4. TROUBLE CRITERION OF MAIN PARTS
MUZ-JP09WA MUZ-JP12WA

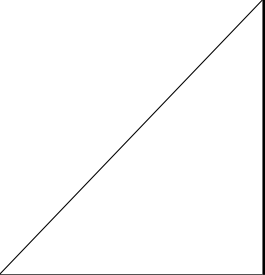
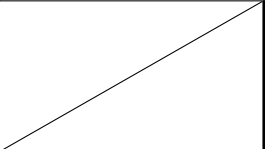
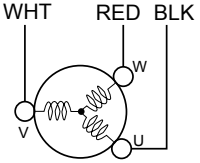
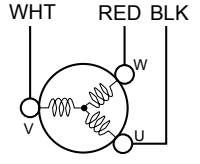
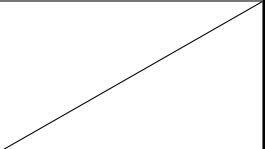
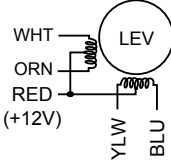
Part name	Check method and criterion	Figure							
Defrost thermistor (RT61) Fin temperature thermistor (RT64) Ambient temperature thermistor (RT65) Outdoor heat exchanger temperature thermistor (RT68)	Measure the resistance with a tester. Refer to 10-6. "Test point diagram and voltage", 1. "Inverter P.C. board", for the chart of thermistor.								
Discharge temperature thermistor (RT62)	Measure the resistance with a tester. Before measurement, hold the thermistor with your hands to warm it up. Refer to 10-6. "Test point diagram and voltage", 1. "Inverter P.C. board", for the chart of thermistor.								
Compressor	Measure the resistance between terminals using a tester. [Temperature: 14 - 104°F (-10 - 40°C)] <table border="1" data-bbox="507 842 834 974"> <thead> <tr> <th></th> <th>Normal (Ω)</th> </tr> </thead> <tbody> <tr> <td>U-V</td> <td rowspan="3">1.68 - 2.04</td> </tr> <tr> <td>U-W</td> </tr> <tr> <td>V-W</td> </tr> </tbody> </table>		Normal (Ω)	U-V	1.68 - 2.04	U-W	V-W		
	Normal (Ω)								
U-V	1.68 - 2.04								
U-W									
V-W									
Outdoor fan motor	Measure the resistance between lead wires using a tester. [Temperature: 14 - 104°F (-10 - 40°C)] <table border="1" data-bbox="520 1076 922 1208"> <thead> <tr> <th>Color of lead wire</th> <th>Normal (Ω)</th> </tr> </thead> <tbody> <tr> <td>RED - BLK</td> <td rowspan="3">26 - 41</td> </tr> <tr> <td>BLK - WHT</td> </tr> <tr> <td>WHT - RED</td> </tr> </tbody> </table>	Color of lead wire	Normal (Ω)	RED - BLK	26 - 41	BLK - WHT	WHT - RED		
Color of lead wire	Normal (Ω)								
RED - BLK	26 - 41								
BLK - WHT									
WHT - RED									
R. V. coil (21S4)	Measure the resistance using a tester. [Temperature: 14 - 104°F (-10 - 40°C)] <table border="1" data-bbox="520 1304 751 1374"> <thead> <tr> <th>Normal (kΩ)</th> </tr> </thead> <tbody> <tr> <td>0.39 - 0.60</td> </tr> </tbody> </table>	Normal (kΩ)	0.39 - 0.60						
Normal (kΩ)									
0.39 - 0.60									
Expansion valve coil (LEV)	Measure the resistance using a tester. [Temperature: 14 - 104°F (-10 - 40°C)] <table border="1" data-bbox="520 1464 971 1630"> <thead> <tr> <th>Color of lead wire</th> <th>Normal (Ω)</th> </tr> </thead> <tbody> <tr> <td>RED - ORN</td> <td rowspan="4">37 - 54</td> </tr> <tr> <td>RED - WHT</td> </tr> <tr> <td>RED - BLU</td> </tr> <tr> <td>RED - YLW</td> </tr> </tbody> </table>	Color of lead wire	Normal (Ω)	RED - ORN	37 - 54	RED - WHT	RED - BLU	RED - YLW	
Color of lead wire	Normal (Ω)								
RED - ORN	37 - 54								
RED - WHT									
RED - BLU									
RED - YLW									

10-5. TROUBLESHOOTING FLOW

A How to check inverter/compressor

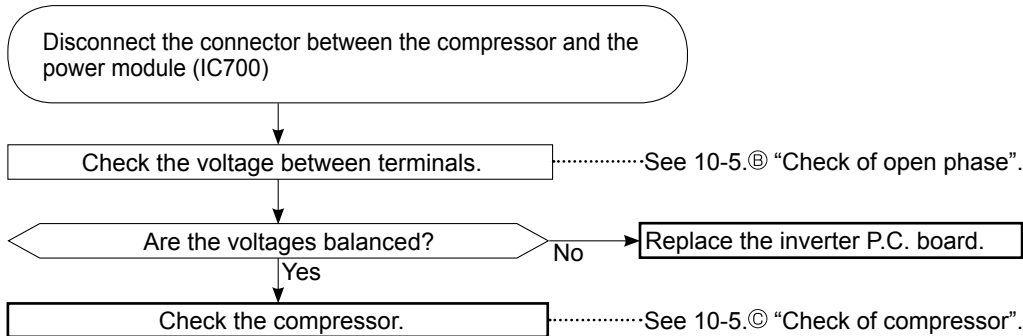

B Check of open phase

- With the connector between the compressor and the power module (IC700) disconnected, activate the inverter and check if the inverter is normal by measuring the **voltage balance** between the terminals.

Output voltage is 50 - 130 V. (The voltage may differ according to the tester.)

<< Operation method >>

Start cooling or heating operation by pressing EMERGENCY OPERATION switch on the indoor unit. (TEST RUN OPERATION: Refer to 7-6.)

<< Measurement point >>

At 3 points

BLK (U)-WHT (V)

BLK (U)-RED (W)

WHT(V)-RED (W)

※ Measure AC voltage between the lead wires at 3 points.

- NOTE:**
1. Output voltage varies according to power supply voltage.
 2. Measure the voltage by analog type tester.
 3. During this check, LED of the inverter P.C. board blinks 9 times. (Refer to 10-6.1.)

C Check of compressor

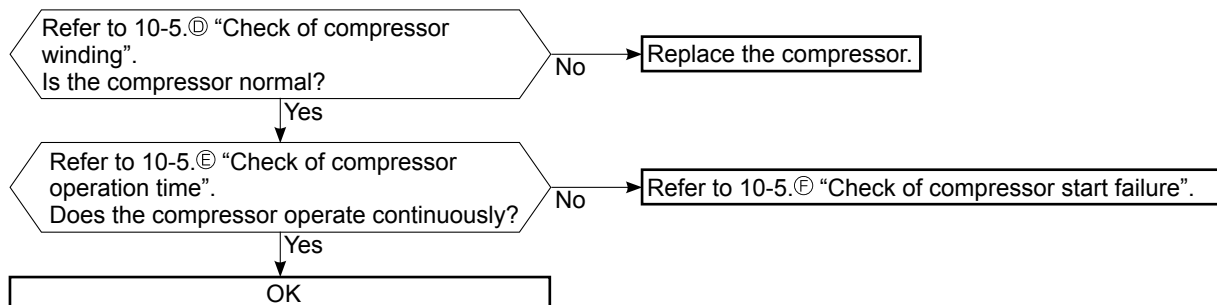

D Check of compressor winding

- Disconnect the connector between the compressor and the power module (IC700) and measure the resistance between the compressor terminals.

<<Measurement point>>

At 3 points

BLK-WHT

BLK-RED

WHT-RED

※ Measure the resistance between the lead wires at 3 points.

<<Judgement>>

Refer to 10-4.

0 [Ω]Abnormal [short]

Infinite [Ω]Abnormal [open]

NOTE: Be sure to zero the ohmmeter before measurement.

E Check of compressor operation time

- Connect the compressor and activate the inverter. Then measure the time until the inverter stops due to overcurrent.

<<Operation method>>

Start heating or cooling operation by pressing EMERGENCY OPERATION switch on the indoor unit. (TEST RUN OPERATION: Refer to 7-6.)

<<Measurement>>

Measure the time from the start of compressor to the stop of compressor due to overcurrent.

<<Judgement>>

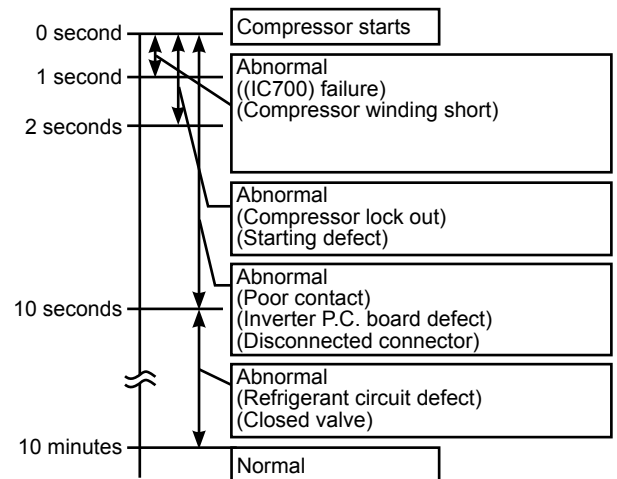

F Check of compressor start failure

Confirm that ①~④ is normal.

•Electrical circuit check

①. Contact of the compressor connector

②. Output voltage of inverter P.C. board and balance of them (See 10-5.⑥)

③. Direct current voltage between DB61(+) and (-) on the inverter P.C. board

④. Voltage between outdoor terminal block S1-S2

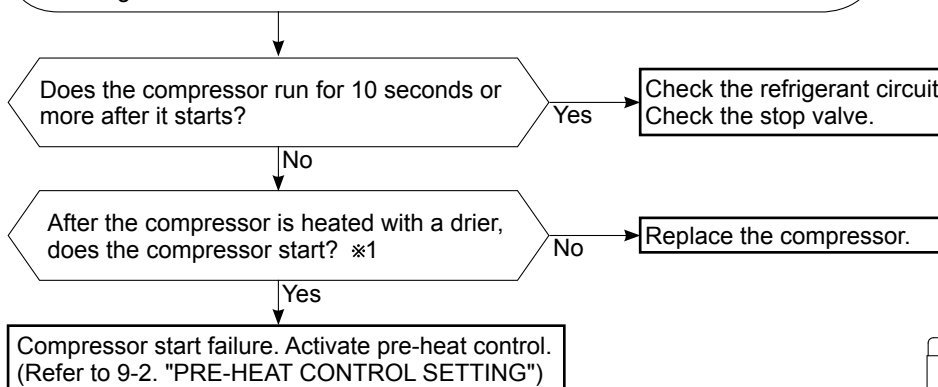

※1
Heat the compressor with a drier for about 20 minutes. Do not recover refrigerant gas while heating.

G Check of outdoor thermistors

Disconnect the connector of thermistor in the inverter P.C. board (see below table), and measure the resistance of thermistor.

Is the resistance of thermistor normal?
(Refer to 10-6.1.)

No

Replace the thermistor except RT64.
When RT64 is abnormal, replace the inverter P.C. board.

Yes

Reconnect the connector of thermistor.
Turn ON the power supply and press EMERGENCY OPERATION switch.

Does the unit operate for 10 minutes or more
without showing thermistor abnormality?

No

Replace the inverter P.C. board.

Yes

OK
(Cause is poor contact.)

Thermistor	Symbol	Connector, Pin No.	Board
Defrost	RT61	Between CN641 pin1 and pin2	Inverter P.C. board
Discharge temperature	RT62	Between CN641 pin3 and pin4	
Fin temperature	RT64	Between CN642 pin1 and pin2	
Ambient temperature	RT65	Between CN643 pin1 and pin2	
Outdoor heat exchanger temperature	RT68	Between CN644 pin1 and pin3	

H Check of R.V. coil

- ※ First of all, measure the resistance of R.V. coil to check if the coil is defective. Refer to 10-4.
- ※ Check if there is 115 V AC at L1 - L2.
- ※ In case CN721 is disconnected or R.V. coil is open, voltage is generated between the terminal pins of the connector although no signal is being transmitted to R.V. coil.
Check if CN721 is connected.

Unit operates in COOL mode even if it is set to HEAT mode.

Disconnect connector between the compressor and the power module (IC700).
Turn ON the power supply and press EMERGENCY OPERATION switch twice (HEAT mode).

Is there 115 V AC between CN721 ① and ② on the inverter P.C. board 3 minutes after the power supply is turned ON?

No

Replace the inverter P.C. board.

Yes

Replace the 4-way valve.

Unit operates in HEAT mode even if it is set to COOL mode.

Disconnect connector between the compressor and the power module (IC700).
Turn ON the power supply and press EMERGENCY OPERATION switch once (COOL mode).

Is there 115 V AC between CN721 ① and ② on the inverter P.C. board 3 minutes after the power supply is turned ON?

Yes

Replace the inverter P.C. board.

No

Replace the 4-way valve.

① Check of outdoor fan motor

Check the connection between the connector CN931 and CN932. Disconnect the connectors CN931 and CN932 from the inverter P.C. board.

Is the resistance between each terminal of outdoor fan motor normal? (Refer to 10-4.)

Yes

Disconnect CN932 from the inverter P.C. board, and turn on the power supply.

Rotate the outdoor fan motor manually and measure the voltage of CN931.
Between 1(+) and 5(-)
Between 2(+) and 5(-)
Between 3(+) and 5(-)

No

(Fixed to either 5 or 0 V DC)

No

Does the voltage between each terminal become 5 and 0 V DC repeatedly?

Yes

No

Does the outdoor fan motor rotate smoothly?

Yes

Replace the outdoor fan motor.

Replace the inverter P.C. board.

J Check of power supply

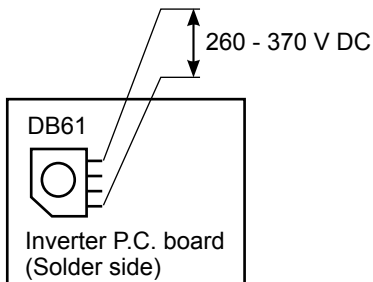
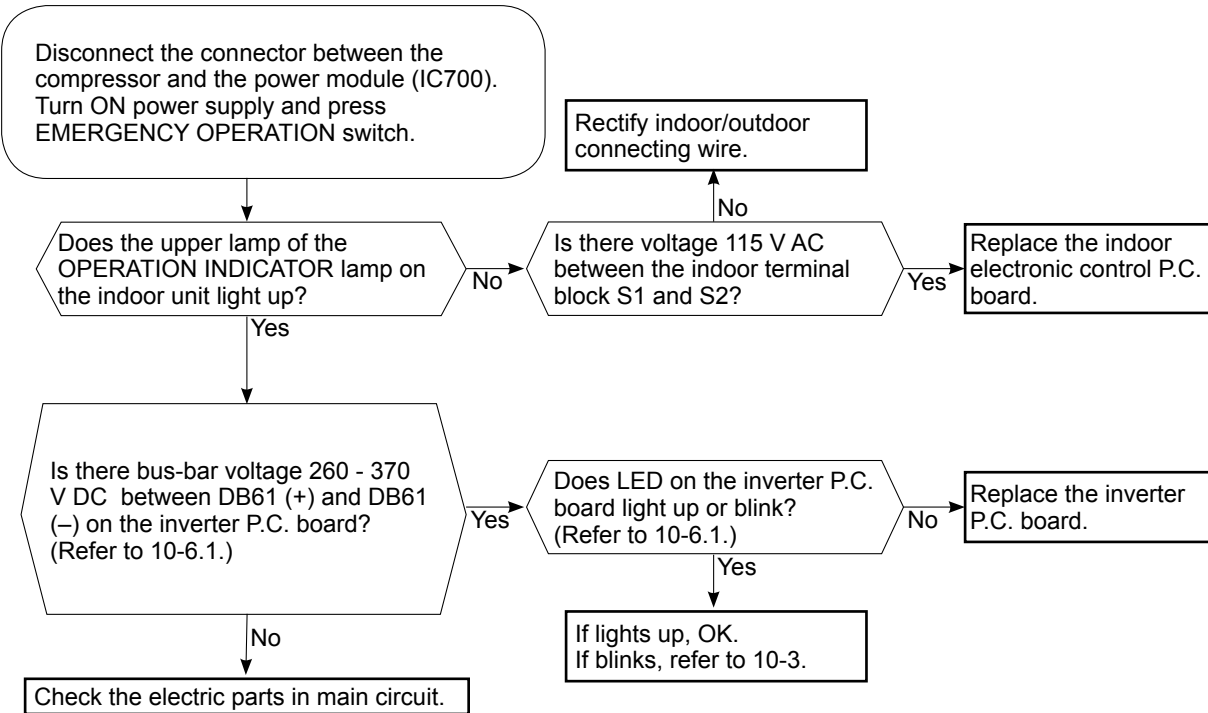

K Check of LEV (Expansion valve)

Turn ON the power supply.
 <Preparation of the remote controller>
 ① While pressing both OPERATION SELECT button and TOO COOL button on the remote controller at the same time, press RESET button.
 ② First, release RESET button.
 Hold down the other 2 buttons for another 3 seconds.
 Make sure that the indicators on the LCD screen shown in the right figure are all displayed. Then release the buttons.

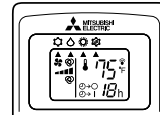
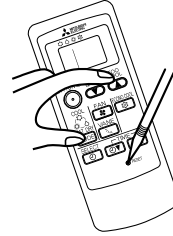

Press STOP/OPERATE (OFF/ON) button of the remote controller (the set temperature is displayed) with the remote controller headed towards the indoor unit. ※1

Expansion valve operates in full-opening direction.

Do you hear the expansion valve "click, click....."?
 Do you feel the expansion valve vibrate when touching it?

Yes → OK

No

Is LEV coil properly fixed to the expansion valve?

No

Properly fix the LEV coil to the expansion valve.

Yes

Does the resistance of LEV coil have the characteristics? (Refer to 10-4.)

Yes

Measure each voltage between connector pins of CN724 on the inverter P.C. board.
 1. Pin③(-) — Pin①(+)
 2. Pin④(-) — Pin①(+)
 3. Pin⑤(-) — Pin①(+)
 4. Pin⑥(-) — Pin①(+)
 Is there about 3 - 5 V AC between each?
NOTE: Measure the voltage by an analog tester.

No

Replace the inverter P.C. board.

No

Replace the LEV coil.

Yes

Replace the expansion valve.

※1. Regardless of normal or abnormal condition, a short beep is emitted once the signal is received.

NOTE: After check of LEV, do the undermentioned operations.

1. Turn OFF the power supply and turn it ON again.
2. Press RESET button on the remote controller.

L Check of inverter P.C. board

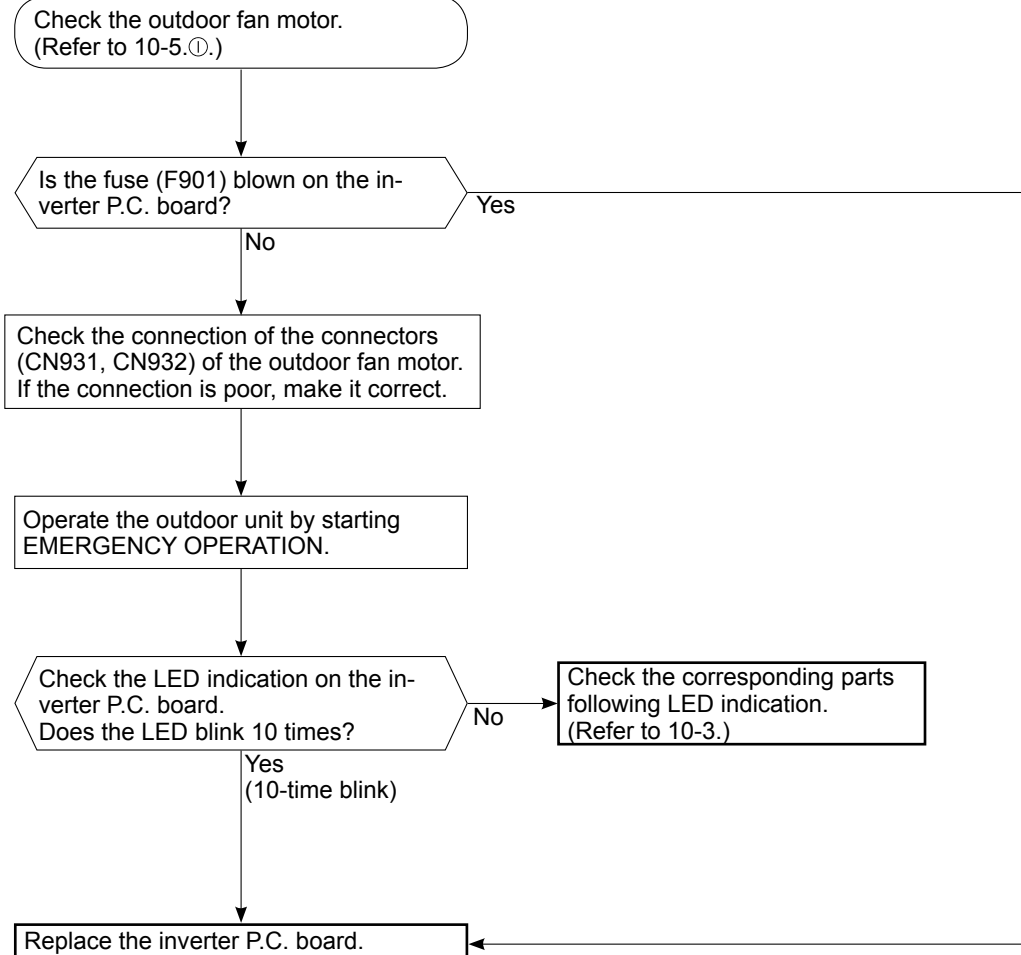

M How to check miswiring and serial signal error

MUZ-JP09/12WA

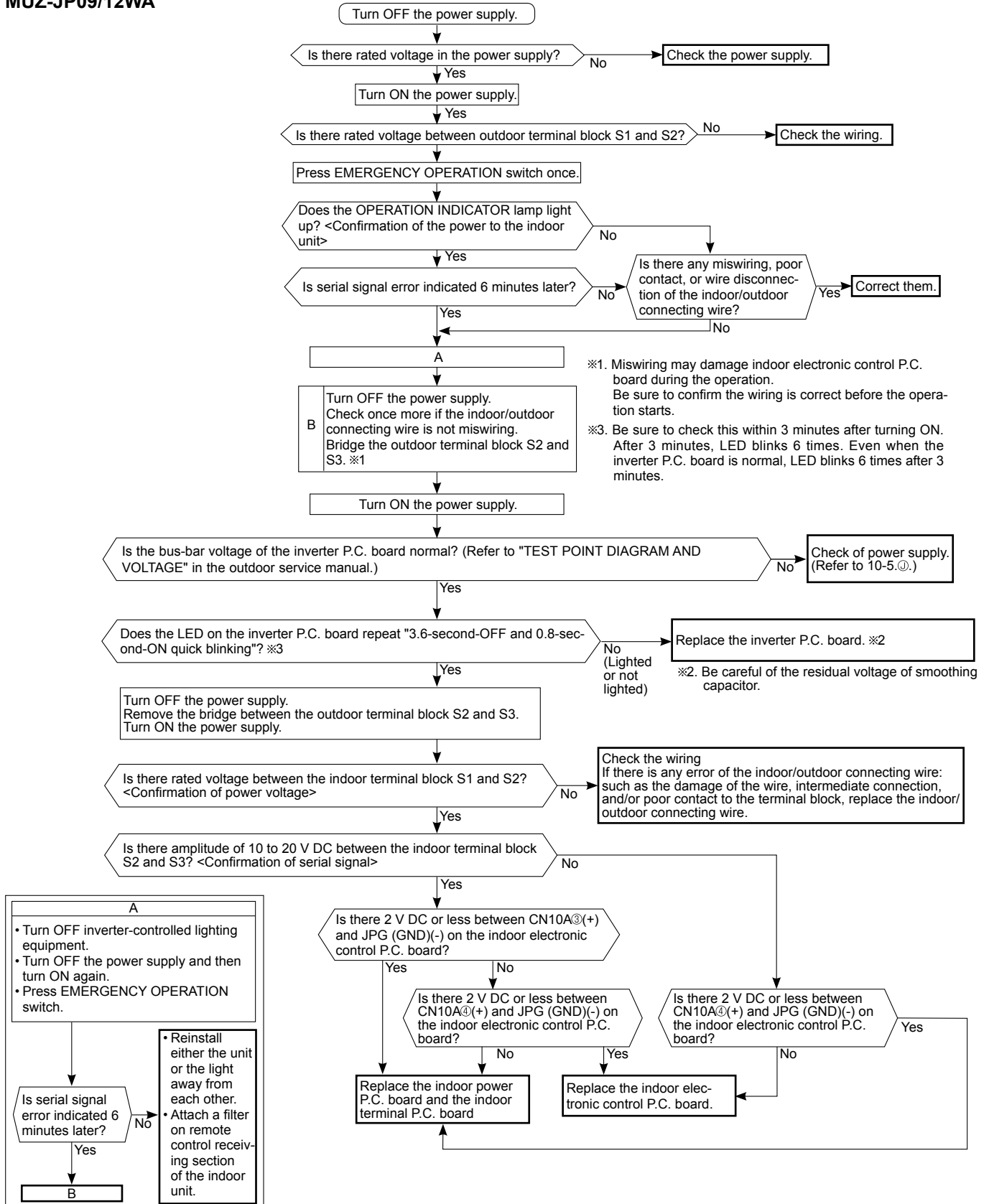

Ⓝ Check of outdoor refrigerant circuit

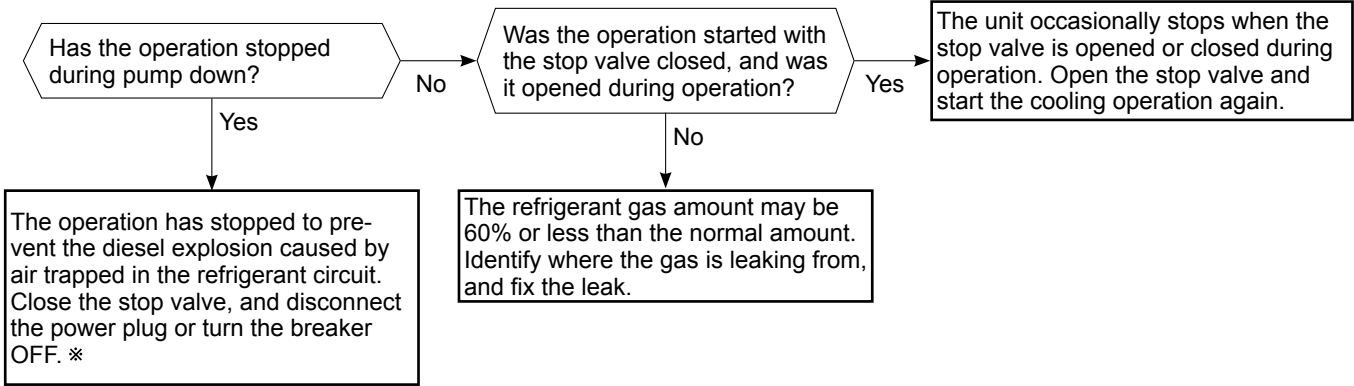

*** CAUTION : Do not start the operation again to prevent hazards.**

① Electromagnetic noise enters into TV sets or radios

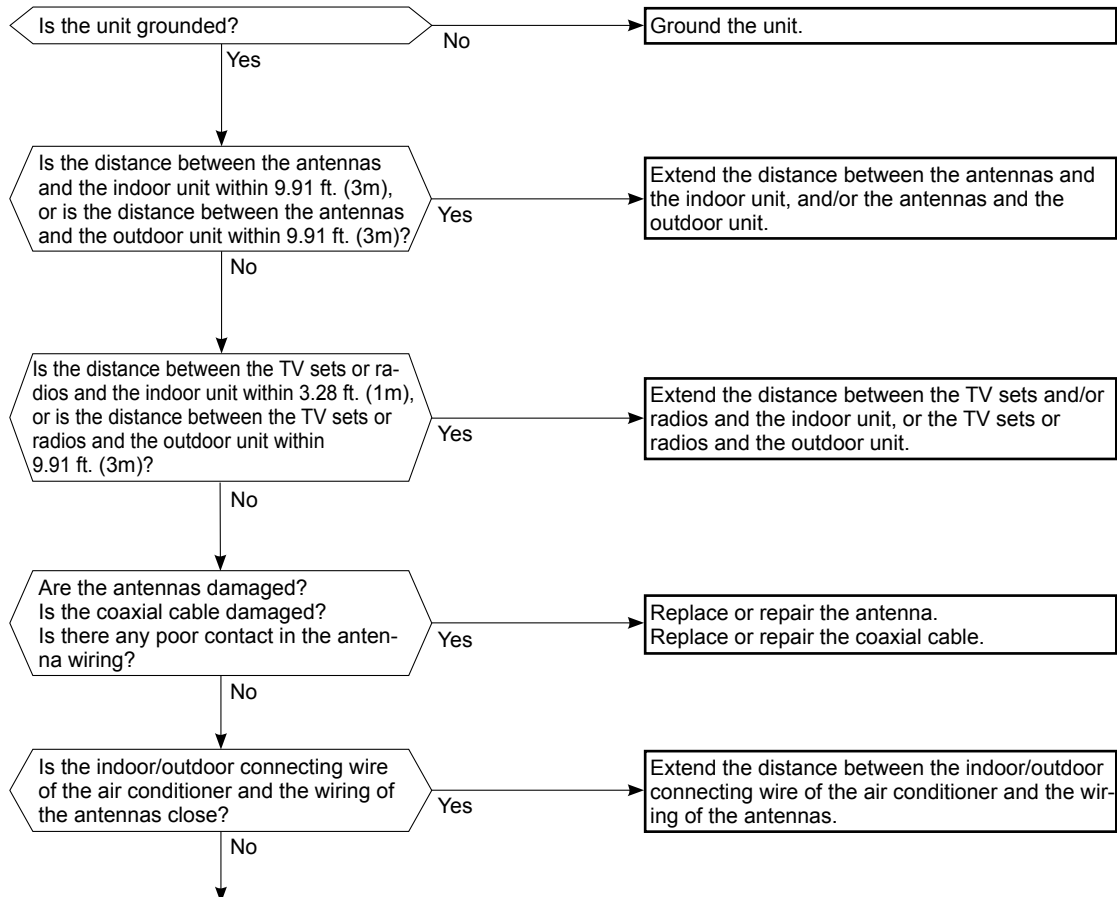

Even if all of the above conditions are fulfilled, the electromagnetic noise may enter, depending on the electric field strength or the installation condition (combination of specific conditions such as antennas or wiring).
 Check the following before asking for service.

1. Devices affected by the electromagnetic noise
 TV sets, radios (FM/AM broadcast, shortwave)
2. Channel, frequency, broadcast station affected by the electromagnetic noise
3. Channel, frequency, broadcast station unaffected by the electromagnetic noise
4. Layout of:
 indoor/outdoor unit of the air conditioner, indoor/outdoor wiring, ground wire, antennas, wiring from antennas, receiver
5. Electric field intensity of the broadcast station affected by the electromagnetic noise
6. Presence or absence of amplifier such as booster
7. Operation condition of air conditioner when the electromagnetic noise enters in
 - 1) Turn OFF the power supply once, and then turn ON the power supply. In this situation, check for the electromagnetic noise.
 - 2) Within 3 minutes after turning ON the power supply, press STOP/OPERATE (OFF/ON) button on the remote controller for power ON, and check for the electromagnetic noise.
 - 3) After a short time (3 minutes later after turning ON), the outdoor unit starts running. During operation, check for the electromagnetic noise.
 - 4) Press STOP/OPERATE (OFF/ON) button on the remote controller for power OFF, when the outdoor unit stops but the indoor/outdoor communication still runs on. In this situation, check for the electromagnetic noise.

10-6. TEST POINT DIAGRAM AND VOLTAGE

1. Inverter P.C. board

MUZ-JP09WA MUZ-JP12WA

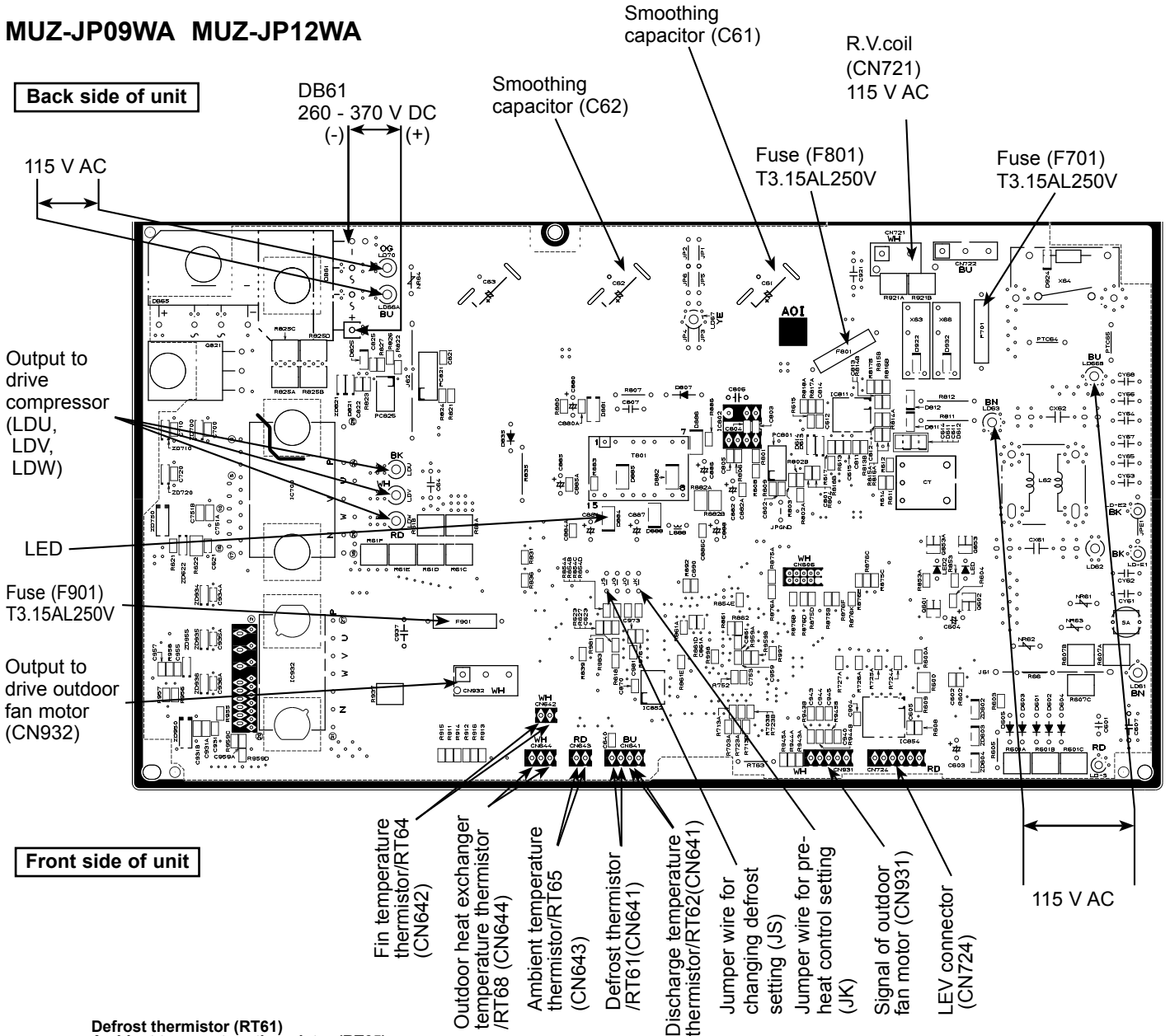

Defrost thermistor (RT61)
Ambient temperature thermistor (RT65)
Outdoor heat exchanger temperature thermistor (RT68)

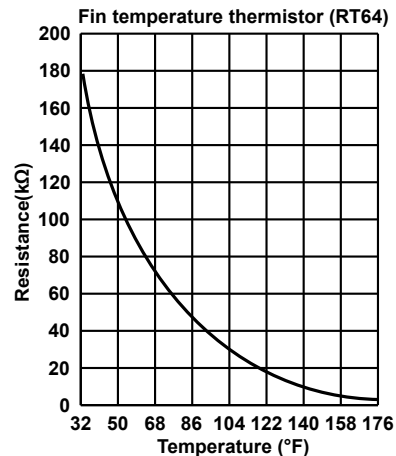
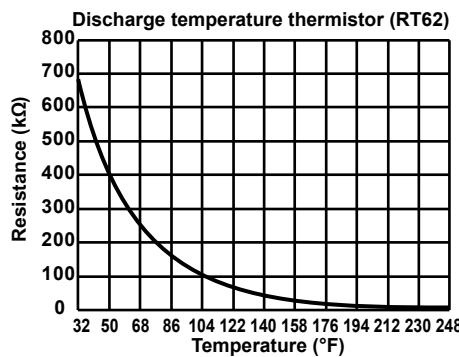
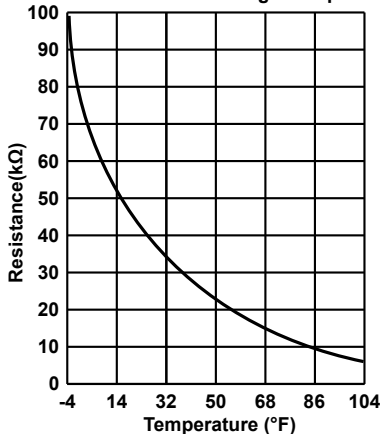

<Detaching method of terminal with locking mechanism>

The terminal which has the locking mechanism can be detached as shown below.

There are 2 types of terminals with locking mechanism.

The terminal without locking mechanism can be detached by pulling it out.

Check the shape of the terminal before detaching.

(1) Slide the sleeve and check if there is a locking lever or not.

(2) The terminal with this connector shown below has the locking mechanism.

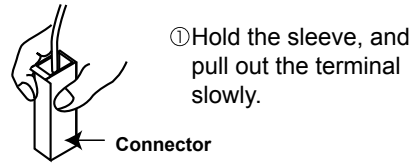
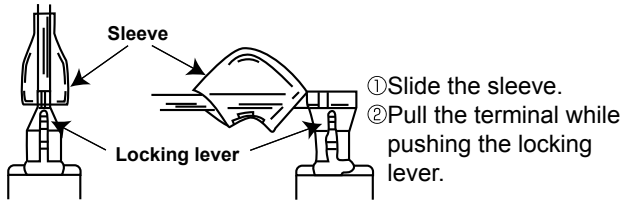

11-1. MUZ-JP09WA MUZ-JP12WA

NOTE: Turn OFF the power supply before disassembly.

—————>: Indicates the visible parts in the photos/figures.
 - - - - ->: Indicates the invisible parts in the photos/figures.

OPERATING PROCEDURE	PHOTOS/FIGURES
<p>1. Removing the cabinet</p> <p>(1) Remove the screw fixing the service panel. (2) Pull down the service panel and remove it. (3) Remove the screws fixing the conduit cover. (4) Remove the conduit cover. (Photo 4) (5) Remove the screw fixing the conduit plate. (Photo 5) (6) Remove the conduit plate. (7) Disconnect the power supply wire and indoor/outdoor connecting wire. (8) Remove the screws fixing the top panel. (9) Remove the top panel. (10) Remove the screws fixing the cabinet. (11) Remove the cabinet. (12) Remove the screws fixing the back panel. (13) Remove the back panel.</p> <p>Photo 2</p>	<p>Photo 1</p> <p>Photo 3</p>

OPERATING PROCEDURE

Photo 4

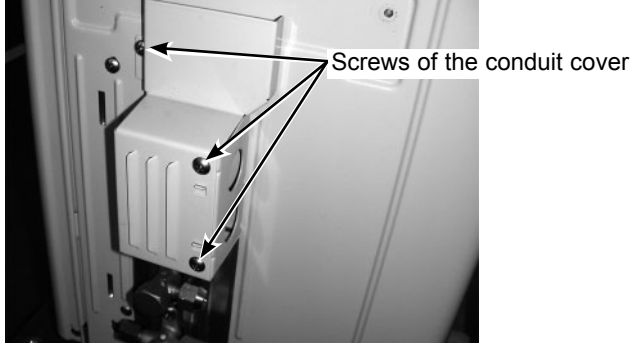

PHOTOS/FIGURES

Photo 5

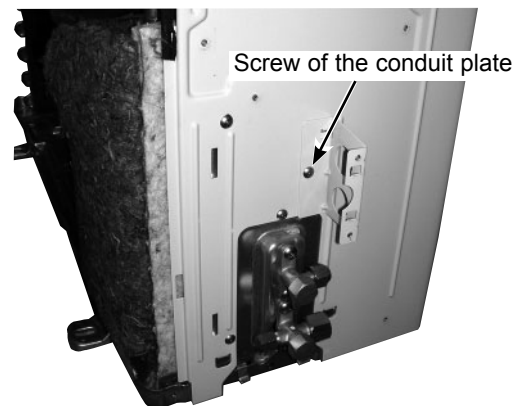

2. Removing the inverter assembly, inverter P.C. board

- (1) Remove the cabinet and panels. (Refer to section 1.)
- (2) Disconnect the lead wire to the reactor and the following connectors:
 - <Inverter P.C. board>
 - CN721 (R.V. coil)
 - CN931, CN932 (Fan motor)
 - CN641 (Defrost thermistor and discharge temperature thermistor)
 - CN643 (Ambient temperature thermistor)
 - CN644 (Outdoor heat exchanger temperature thermistor)
 - CN724 (LEV)
- (3) Remove the compressor connector (CN61).
- (4) Remove the screws fixing the heat sink support and the separator.
- (5) Remove the fixing screws of the terminal block support and the back panel.
- (6) Remove the inverter assembly.
- (7) Remove the screw of the ground wire and screw of the terminal block support.
- (8) Remove the heat sink support from the P.C. board support.
- (9) Remove the screw of the inverter P.C. board and remove the inverter P.C. board from the P.C. board support.

Photo 6

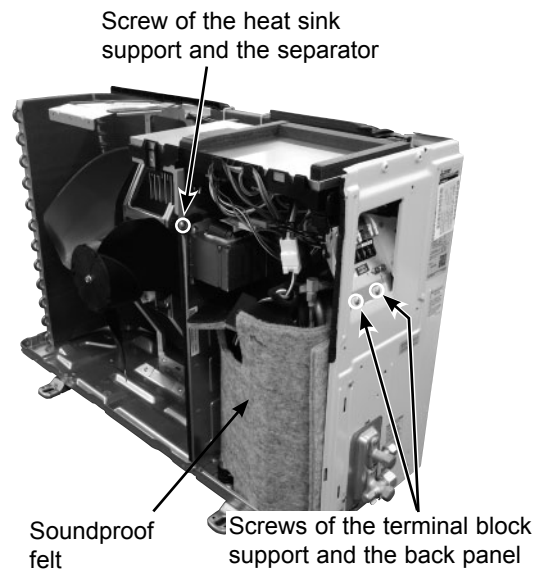

3. Removing R.V. coil

- (1) Remove the cabinet and panels. (Refer to section 1.)
- (2) Disconnect the following connectors:
 - <Inverter P.C. board>
 - CN721 (R.V. coil)
- (3) Remove the R.V. coil.

Photo 7



OPERATING PROCEDURE

4. Removing the discharge temperature thermistor, defrost thermistor, outdoor heat exchanger temperature thermistor and ambient temperature thermistor

- (1) Remove the cabinet and panels. (Refer to section 1.)
- (2) Disconnect the lead wire to the reactor and the following connectors:
<Inverter P.C. board>
CN641 (Defrost thermistor and discharge temperature thermistor)
CN643 (Ambient temperature thermistor)
CN644 (Outdoor heat exchanger temperature thermistor)
- (3) Pull out the discharge temperature thermistor from its holder.
- (4) Pull out the defrost thermistor from its holder.
- (5) Pull out the outdoor heat exchanger temperature thermistor from its holder.
- (6) Pull out the ambient temperature thermistor from its holder.

PHOTOS/FIGURES

Photo8

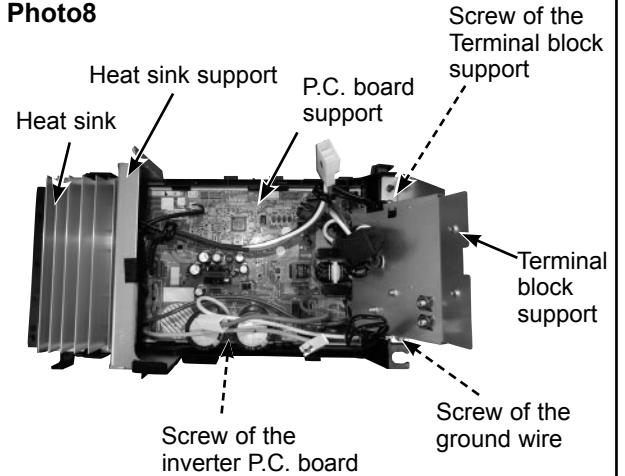

Photo 9

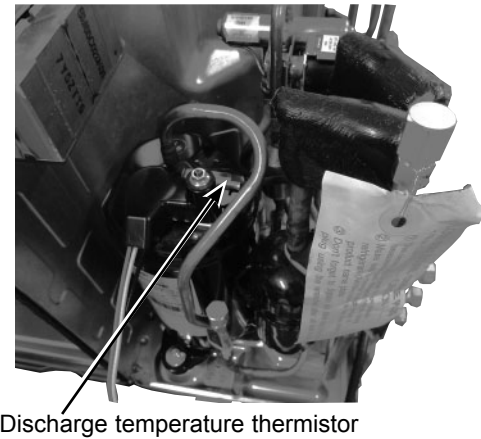
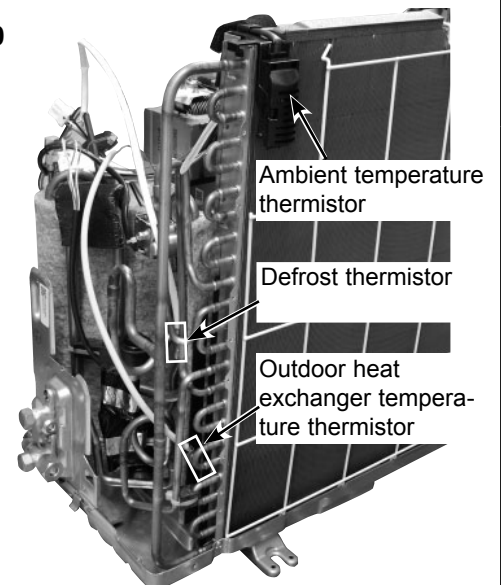

Photo 10



OPERATING PROCEDURE

5. Removing outdoor fan motor

- (1) Remove the cabinet and panels. (Refer to section 1.)
- (2) Disconnect the following connectors:
<Inverter P.C. board>
CN931, CN932 (Fan motor)
- (3) Remove the propeller fan nut.
- (4) Remove the propeller fan.
- (5) Remove the screws fixing the fan motor.
- (6) Remove the fan motor.

NOTE: The propeller fan nut is a reverse thread.

PHOTOS/FIGURES

Photo 11

Screws of the outdoor fan motor

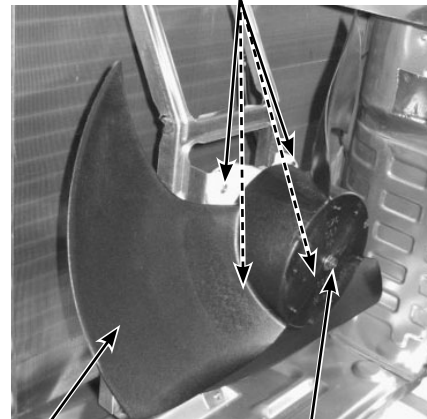

Propeller fan

Propeller fan nut

6. Removing the compressor and 4-way valve

- (1) Remove the cabinet and panels. (Refer to section 1.)
- (2) Remove the inverter assembly. (Refer to section 2.)
- (3) Remove the screws fixing the reactor.
- (4) Remove the reactor.
- (5) Remove the soundproof felt.
- (6) Recover gas from the refrigerant circuit.
NOTE: Recover gas from the pipes until the pressure gauge shows 0 PSIG.
- (7) Detach the brazed part of the suction and the discharge pipe connected with compressor.
- (8) Remove the nuts fixing the compressor.
- (9) Remove the compressor.
- (10) Detach the brazed part of pipes connected with 4-way valve.

Photo 12

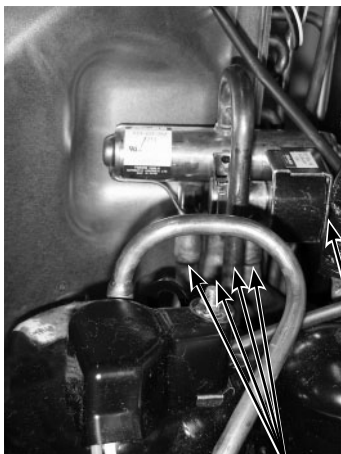

Screw of the
R.V. coil

Brazed parts of
4-way valve

Photo 13

Screws of
the reactor



Discharge pipe
brazed part

Suction pipe
brazed part

mitsubishi electric corporation

HEAD OFFICE: TOKYO BUILDING, 2-7-3, MARUNOUCHI, CHIYODA-KU, TOKYO 100-8310, JAPAN

© Copyright 2018 MITSUBISHI ELECTRIC CORPORATION

Issued: Jan. 2019. No. OBH821 REVISED EDITION-A

Published: Nov. 2018. No. OBH821

Made in Japan

Specifications are subject to change without notice.