

# ECO-VENTILATION



SINGLE-ROOM  
ENERGY RECOVERY  
VENTILATORS



**TWINFRESH EXPERT RW1-85-2 V.2**

SMART HOUSE

*Fresh air  
in your house!*



# SINGLE-ROOM ENERGY RECOVERY VENTILATORS

## TwinFresh Expert is a new series of single-room energy recovery ventilators

TwinFresh Expert is the most state-of-the-art and efficient solution for a comfortable indoor climate and required air exchange in renovated premises, brand new recently inhabited houses or reconstructed apartments.

### Features of TwinFresh Expert RW1-85-2 V.2 ventilators

- ▶ Controlled by Android or iOS smartphone through the cloud server from any part of the world.
- ▶ One TwinFresh Expert unit in ventilation mode can serve rooms up to 500 sq. ft\*
- ▶ Wi-Fi communication between several ventilators for coordinated operation.
- ▶ Efficient supply and exhaust single-room ventilation with air flow up to 50 CFM.
- ▶ High-tech ceramic heat exchanger with regeneration efficiency up to 70 %.
- ▶ Reversible DC motors with low energy demand from 3.78 W and safe voltage of 12 V.
- ▶ Integrated control system.
- ▶ Silent operation from 0.5 Sones.
- ▶ Easy mounting and maintenance.
- ▶ Air cleaning with total MERV 5 class filters (optionally MERV 14 filter).
- ▶ Rated for non-stop operation.
- ▶ Frost- and condensate-free.

\*In accordance with ANSI/ASHRAE Standard 62.2-2016



### Ceramic energy accumulator (regenerator)

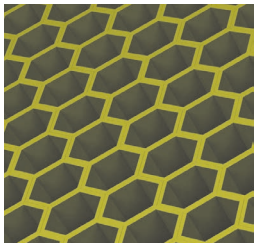

The high-tech ceramic regenerator with heat recovery efficiency up to 70 % is used for heating of supply air by means of the exhaust air heat recovery. Due to its honeycomb structure, the unique heat exchanger has larger air contact area and excellent heat conducting and accumulating properties.

One of the best heat recovery efficiency on the market due to innovative hexagonal structure of the heat exchanger cells



Open



Closed

The specially designed front panel provides 100 % air tightness and protection from wind.



Easy maintenance. Indoor unit is opened by a light press on the latches on both sides.



Integrated air shutters prevent air back drafting

Decorative front panel





**Reversible DC fan**

Air is supplied or exhausted by a reversible axial fan with DC motor. Due to DC technology the fan has outstanding low energy demand. The fan is powered by safe voltage 12 V. The motor has integrated overheating protection and ball bearings for long service life.

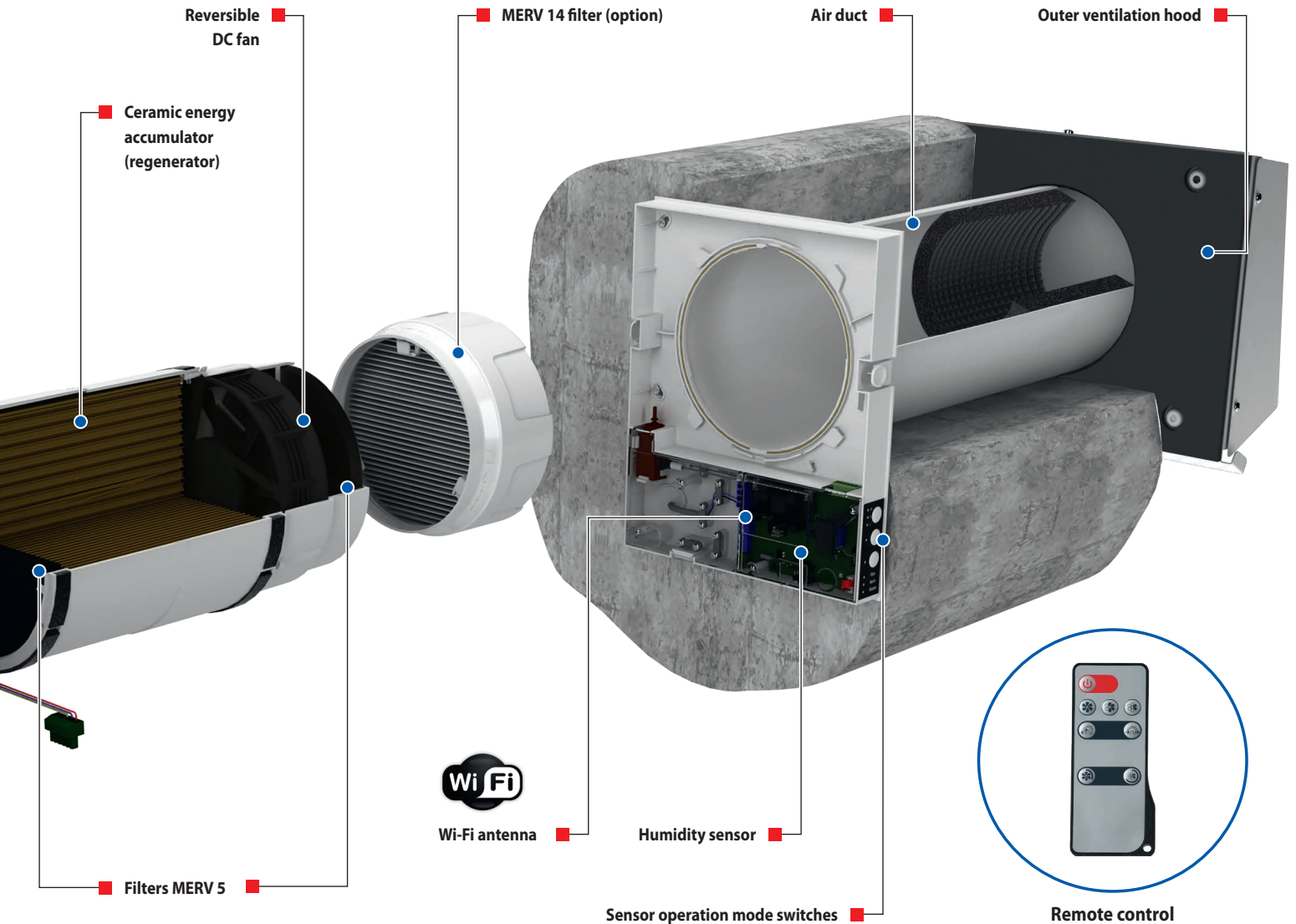

**Air filters**

The two integrated air filters with total filtration rate MERV 5 provide supply and exhaust air filtration. The filters prevent ingress of dust and insects into the supply air and contamination of the ventilator parts. The filters also have antibacterial treatment. The filter cleaning is done with a vacuum cleaner or water flushing. MERV 14 filter with the filtration class PM2.5 99 % is available as a specially ordered accessory.\*

\* Reduces the air flow down to 40 CFM when installed.



## Operation of TwinFresh ventilators

The ventilator is designed both for reversible mode with energy regeneration and supply or exhaust mode with no regeneration.

- ▶ **CYCLE I.** Warm stale air is exhausted from the premise, flows through the ceramic regenerator and transfers up to 70 % of the accumulated heat and moisture to it. As the ceramic regenerator gets warmed up, the ventilator switches to the supply mode.
- ▶ **CYCLE II.** Clean cold intake air flows through the regenerator and absorbs accumulated heat and humidity. In 70 seconds, after cooling of the ceramic regenerator, the ventilator is switched to the exhaust air mode and a new cycle starts.

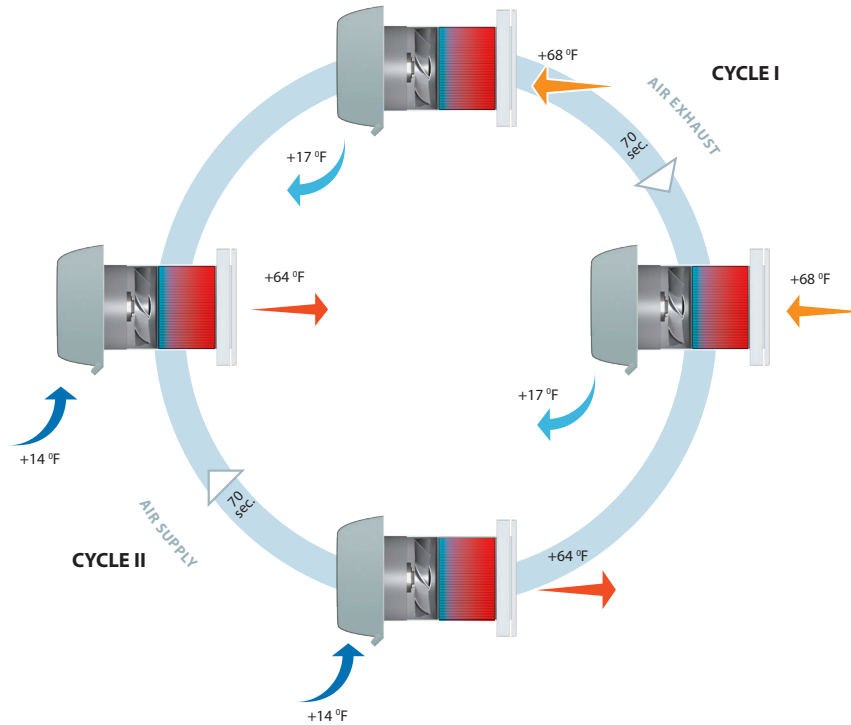

## Control

The ventilator is controlled means of:



control panel



remote control



smartphone application

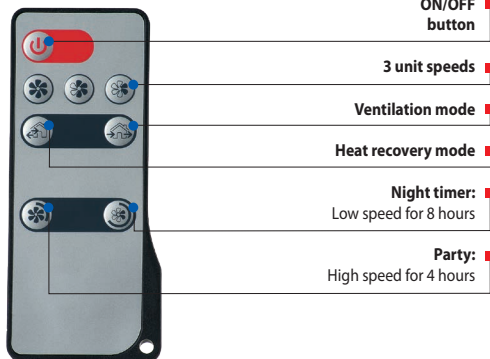
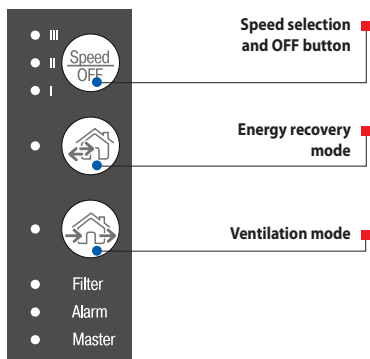

## Control

Connection of several ventilators via Wi-Fi for synchronous operation. Ventilation control via cloud service worldwide. Connection to Smart Home or BMS via Wi-Fi.



The app is available on the App Store and Google Play.



Download on the  
**App Store**



Google Play



## Mounting

The ventilator is designed for through-the-wall installation inside a prepared hole in an outer wall of the building.

The best ventilation solution is pairwise installation of reverse phase connected ventilators when some units ensure supply of fresh air to the room and the other units exhaust air from the premise. This way the most efficient balanced ventilation is arranged.

In case of brand new construction, the ventilators are mounted in two stages:

1. Pre-installation at the stage of the indoor finishing and outer decorative wall finishing. It includes installation of an air duct, an outer ventilation hood and cable installation.
2. Final mounting before commissioning of a house. It includes installation of a regenerator with a fan and filters and mounting and wiring of an indoor unit with a controller and shutters.

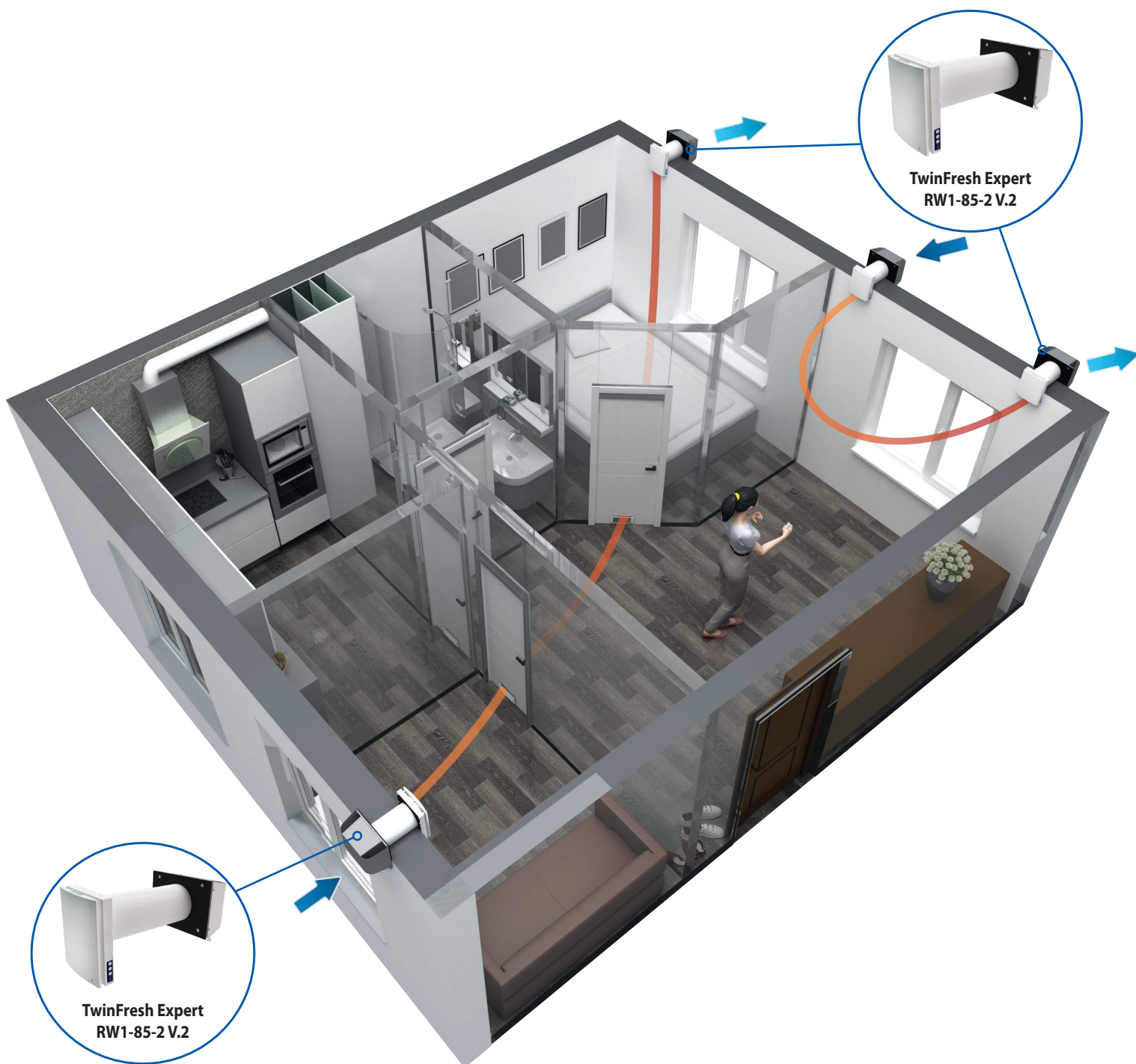

## Technical data







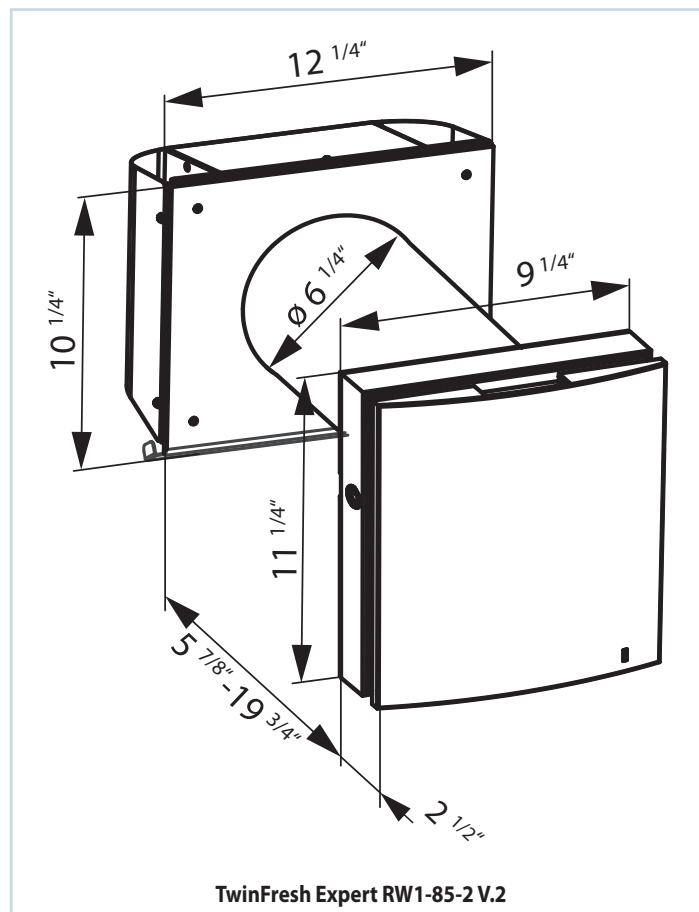



Model	TwinFresh Expert RW1-85-2 V.2			
Speed	1	2	3	max
Voltage / 50 (60) Hz [V]	1~100-240			
Power consumption [W]	3.78	4.71	6.85	10.55
Current consumption [A]	0.048	0.056	0.075	0.106
Air flow in ventilation mode [CFM]	9	18	29	50
Air flow in regeneration mode [CFM]	4	9	15	25
RPM	1050	1600	2270	2930
Sound pressure level @ 3 ft [Sones]	0.7	1.5	3.0	4.3
Sound pressure level @ 10 ft [Sones]	0.5	0.7	1.5	2.1
Outdoor sound pressure attenuation [Sones]	2.5			
Transported air temperature [°F]	from +5 up to +104			
Regeneration efficiency [%]	≤ 70			
Regenerator type	Ceramic			
Filter	MERV 5, MERV 14 (option)*			
Ingress protection	IP24			

\* MERV14 filter decreases airflow from 50 CFM to 40 CFM

## Overall dimensions [in]



**Accessories**

Accessory image	Accessory name	Description	Accessory image	Accessory name	Description
	EH-20 160	Stainless steel outer hood for thin walls		SF TwinFresh R50 G3	MERV5 filter set (2 pcs.)
	EH-2 grey 160	Grey steel outer hood for thin walls		Completion kit TwinFresh Expert RA1-50	Indoor unit cartridge with regenerator, fan and two filters sound-insulating material remote control
	EH-2 chrome 160	Polished stainless steel hood for thin walls		Duct 160-500	Air duct 500 mm
	T TwinFresh Expert R-50	Cardboard template for indoor unit installation		RC1 TwinFresh	Remote control
	SF TwinFresh Expert R-50 F8	Option: MERV 14 Filter (1 piece)		CO2-2	CO <sub>2</sub> sensor with a LED CO <sub>2</sub> concentration indicator and a touch button to switch the CO <sub>2</sub> sensor operation mode

Tel: 888-640-0925  
513-348-3853  
Fax: 513-268-4597

Sales@ventsus.com  
VentsUS.com  
400 Murray Road,  
Cincinnati OH 45217

**VENTS reserves the rights to modify any of its products' features, designs, components and specifications at any time and without notice to maintain the development and quality of manufactured goods.**

2021-06

